



Before installation please observe the following points:

- Read all information in this manual carefully. All suspension components are fitted and removed acc. to the manufacturer's specifications for fitting and removing, if not otherwise required in these instructions.
- Check that your vehicle type is listed in the certificate as being released for this kit.
- Check the product for all components before starting installation!
- Check that dimensions and fastening points are comparable between the original and Bilstein shock absorbers.
- Remove the negative battery pole.
- Directional references (left, right, front, rear) are always with reference to the driving direction.
- The test vehicles are left- hand drive cars.

After installation please observe the following points:

- Set the vehicle height by adjusting spring plates and lock nuts on the new dampers. Only use the supplied spanner wrenches.
- After installing the suspension system, caster and camber must be checked and adjusted according to manufacturer's specifications. Check and reset load- dependent brake compensator and ABS system according to manufacturer's specifications.
- Check and adjust headlight aim.
- Because the vehicle has been lowered, freedom of movement for all wheel-/ tire- combinations must be checked.
- All rubber- mounted strut/ damper attachments must not be fully tightened until AFTER the suspension system is loaded (wheels on the ground). Other mounting fasteners (for example brackets) must be securely tightened BEFORE load is placed on the suspension system.
- Connect the negative battery pole.
- All diagrams are generalized and not to scale! brackets, etc. specific to strut are not shown!

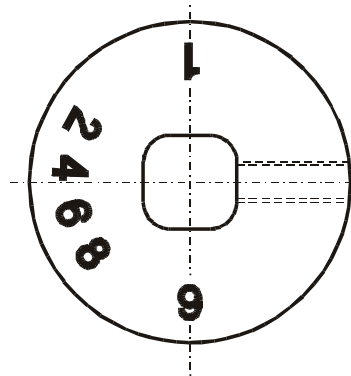

position **9** = **comfort** (clockwise direction)
 position **1** = **sport** (counter- clockwise direction)

During the adjustment you will hear a positive „click“ at each position of the adjustment.

Instruction for the front axle

The adjusting element of the front struts is located at the bottom edge of the strut, covered by a blue plastic cap. That cap must be removed before adjusting. After the adjustment the cap must be replaced again.

list of torques

	M8	M 10	M 12	M 14	M 16	Thread
	13	25	45	72	110	Torque Nm
	10	19	34	54	83	Torque ft lb

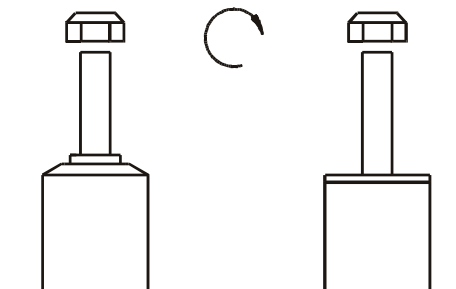

DO NOT USE IMPACT TOOLS FOR LOOSENING OR TIGHTENING FASTENERS, BECAUSE THIS MAY DESTROY THE THREADS. SELF- LOCKING NUTS MUST ONLY BE **USED ONCE!**

Removal

Place vehicle on a chassis hoist, lift it and remove wheels.



The lower control arm must be supported by suitable means!

Remove bottom mount.

Remove top fixing nuts from support bearing.
Do not remove center nut at this time!

Remove complete strut and clamp it in an appropriate strut vise.

Using a suitable spring compressor, compress suspension spring until tension on support bearing is released.

Release center nut and remove original mounting parts and coil spring. Please refer to diagram to identify which parts will be replaced with BILSTEIN- supplied components.

Installing

Assemble BILSTEIN and/ or original mounting parts, as well as the new BILSTEIN spring on the BILSTEIN strut in reverse sequence of removal.



IMPORTANT! Spring plates must not be adjusted outside the range specified below!

The correct mounting position of the suspension springs can be determined by the printing on the springs; install them with the print upright.

Do not reuse original- bumper, since BILSTEIN- strut has built in bump stop.

Fit assembled BILSTEIN strut to the vehicle in reverse sequence of removal.

IMPORTANT!

The adjustment range of the spring plates is only approved within the range of the values given in Point 1. Adjustment must be carried out so that the body is level when the vehicle is empty apart from the driver. The lowest approved adjustment and the permissible adjustment range are to be entered, stating the fixed axle reference points. (Example, see below).

Manufacturer	FORD	
ABE-/ EG- BE- No.	e13*2001/116*0144*.. e13*2001/116*0157*..	
type designation	DA3/ DB3	
model	FORD Focus, from model year 2004 all models	

Manufacturer	MAZDA	
ABE-/ EG- BE- No.	e1*2001/116*0234*..	
type designation	BK	
model	MAZDA 3	

Manufacturer	VOLVO	
ABE-/ EG- BE- No.	e4*2001/116*0076*..	
type designation	M	
model	VOLVO S40, VOLVO V50, VOLVO C30	

FRONT	maximum permissible axle load 1100 kg (2420 lb)	
spring part number	main spring: E4-FD1-Y960A00	helper spring: E4-FD1-Z349A00
shock absorber part number	VE3-C119/ VE3-C120 (left side/ right side) without damping force adjustment VM3-C123/ C124 (left side/ right side) with damping force adjustment	
permissible adjustment range	225 – 240 mm* = 15 mm range	
* measurement:	top edge of spring seat down to the center of bottom mounting screw at strut fixing bolt	

REAR	maximum permissible axle load 1090 kg (2398 lb)	
spring part number	main spring: E4-FD1-Y961A00	
shock absorber part number	BE5-C121 without damping force adjustment BM5-C125 with damping force adjustment	
permissible adjustment range	45 – 50 mm* = 5 mm range	
* measurement:	bottom edge of spring seat up to top of original spring seat	

- There are no technical objections against the use of all O.E. wheel/tyre combinations.
- There is also no technical reason to object to the use of special wheel/tyre combinations, provided the following conditions are met:
 - Special TÜV assessments or approvals have been obtained for the relevant wheel/tyre combination and the necessary conditions are met.
 - If the series bump travel limitation has to be modified as a result of conditions laid down in these test reports (e.g. change of O.E. bump stops or installation of additional bump travel limiters), the characteristic line of the axle suspension has to be verified and assessed new (assessment acc. to §21 StVZO).
- The ground clearance in unladen state is reduced by the installation of special springs. It is the approximate equivalent of that of a partially laden series vehicle. When the vehicle is loaded to the admissible axle loads the ground clearance does not change as compared to the series vehicle. If spoilers, rear aprons and special exhaust systems are mounted, however, the reduced angle of slope must be noted (travelling on ramps etc.).
- The specified minimum height of the coupling ball above the road surface with the permissible total weight of the vehicle (acc. DIN 74058) is 350 mm.

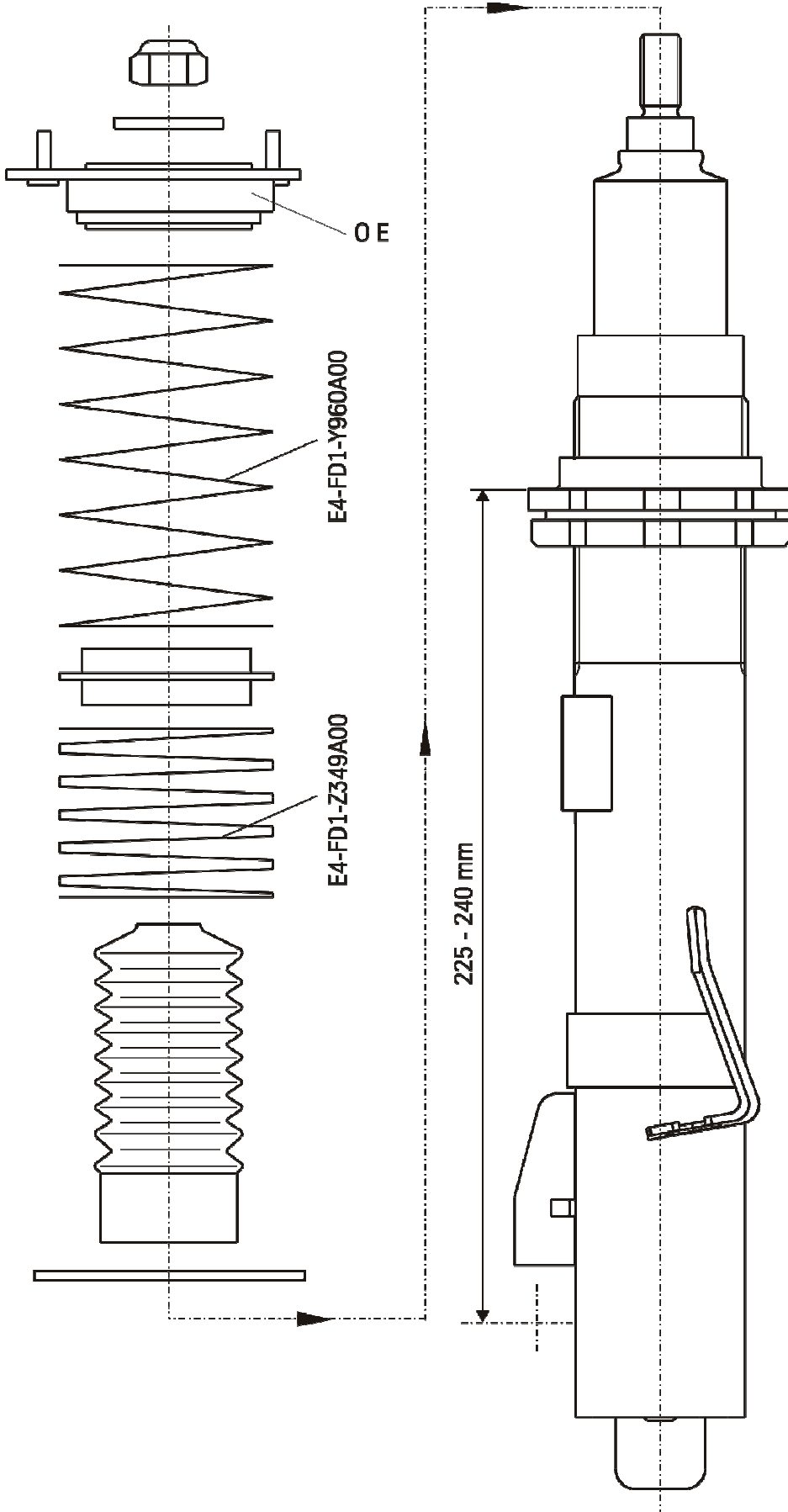

Removal

Place vehicle on a chassis hoist, lift it and remove wheels.



The lower control arm must be supported by suitable means!

Remove top and bottom fixing mount from support bearing.

Remove original shock absorber and original mounting parts.

Installing

Fit BILSTEIN mounting parts on BILSTEIN shock absorber according to the sketch below.

Fit BILSTEIN shock absorber to the vehicle in reverse sequence of removal.

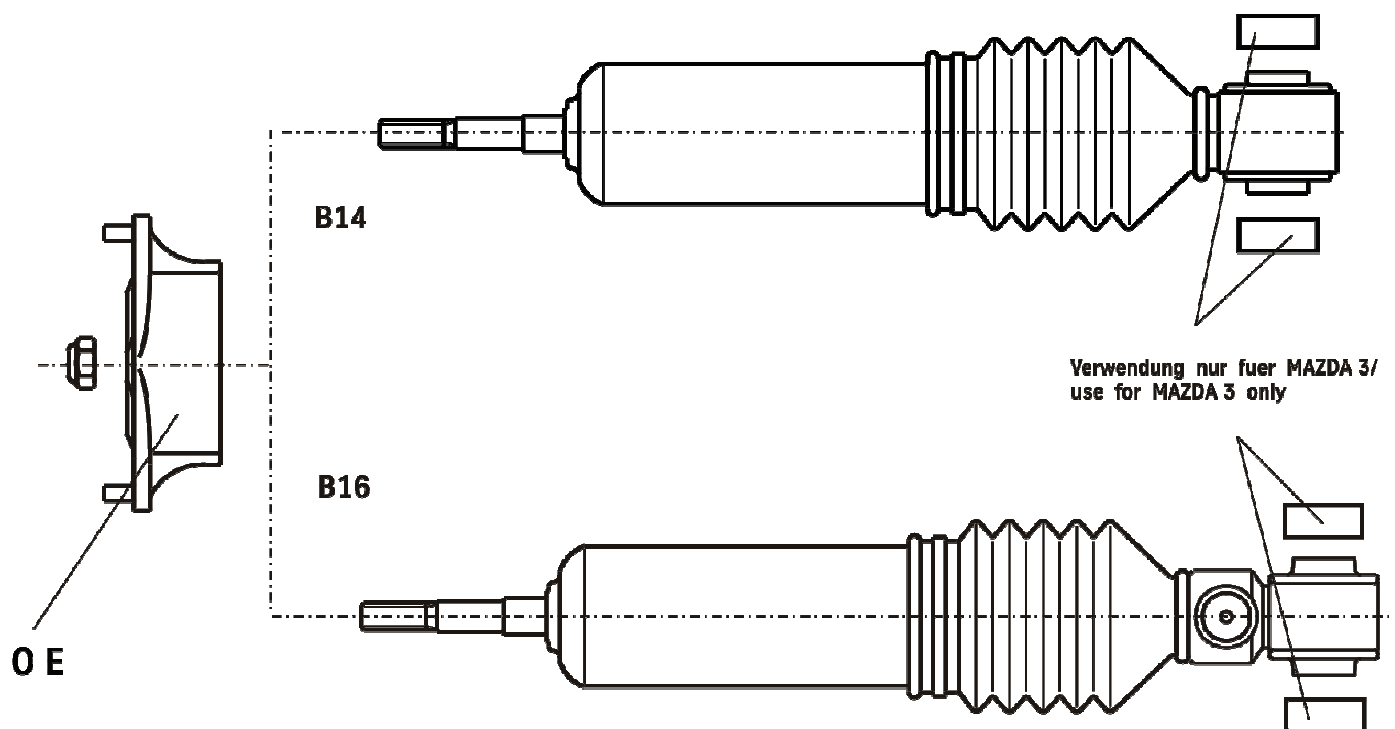

- mounting instruction for rear axle height adjustment

