



**BMW E36 sedan**  
**BMW E36 touring**  
**BMW E36 coupe**  
**BMW E36 convertible**



- **ist of torques**

	M 8	M 10	M 12	M 14	M 16	Thread
	13	25	45	72	110	Torque Nm
	10	19	34	54	83	Torque ft lb

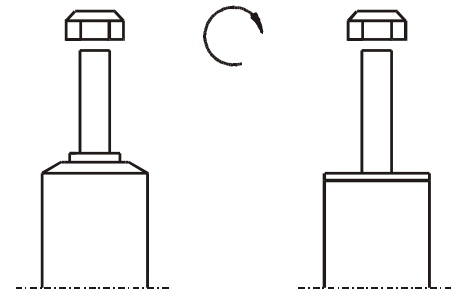

DO NOT USE IMPACT TOOLS FOR LOOSENING OR TIGHTENING FASTENERS, BECAUSE THIS MAY DESTROY THE THREADS. SELF- LOCKING NUTS MUST ONLY BE **USED ONCE!**

**After installation please observe the following points:**

After installing the suspension system, caster and camber must be checked and adjusted according to manufacturer's specifications.

Check and reset load- dependent brake compensator and ABS system according to manufacturer's specifications.

Check and adjust headlight aim.

Because the vehicle has been lowered, freedom of movement for all wheel-/ tire- combinations must be checked.

ALL RUBBER- MOUNTED STRUT/ DAMPER ATTACHMENTS MUST NOT BE FULLY TIGHTENED UNTIL AFTER THE SUSPENSION SYSTEM IS LOADED (WHEELS ON THE GROUND). OTHER MOUNTING FASTENERS (FOR EXAMPLE BRACKETS) MUST BE SECURELY TIGHTENED BEFORE LOAD IS PLACED ON THE SUSPENSION SYSTEM.

ALL DIAGRAMS ARE GENERALIZED AND NOT TO SCALE! BRACKETS, ETC. SPECIFIC TO STRUT ARE NOT SHOWN!

## Remove

Place vehicle on a chassis hoist, lift it and remove wheels.

Vehicles equipped **with xenon headlight** the sensor for the headlamp levelling controller must be removed before.



***The lower control arm must be supported by suitable tools***

Remove bottom mount.

Remove top fixing nuts from support bearing. Do not remove center nut at this time!

Remove complete strut and clamp it in an appropriate strut vise.

Using a suitable spring compressor, compress suspension spring until tension on support bearing is released.

Release center nut and remove original mounting parts and coil spring. Please refer to diagram to identify which parts will be replaced with BILSTEIN-supplied components.

## Install

Assemble BILSTEIN and/ or original mounting parts, as well as the new BILSTEIN spring on the BILSTEIN strut in reverse sequence of removal.



***IMPORTANT! Spring plates must not be adjusted outside the ranges specified below!***

The correct mounting position of the suspension springs can be determined by the printing on the springs; install them with the print upright.

Do not reuse original-bumper, since BILSTEIN-strut has built in bump stop.

Fit assembled BILSTEIN strut to the vehicle in reverse sequence of removal.

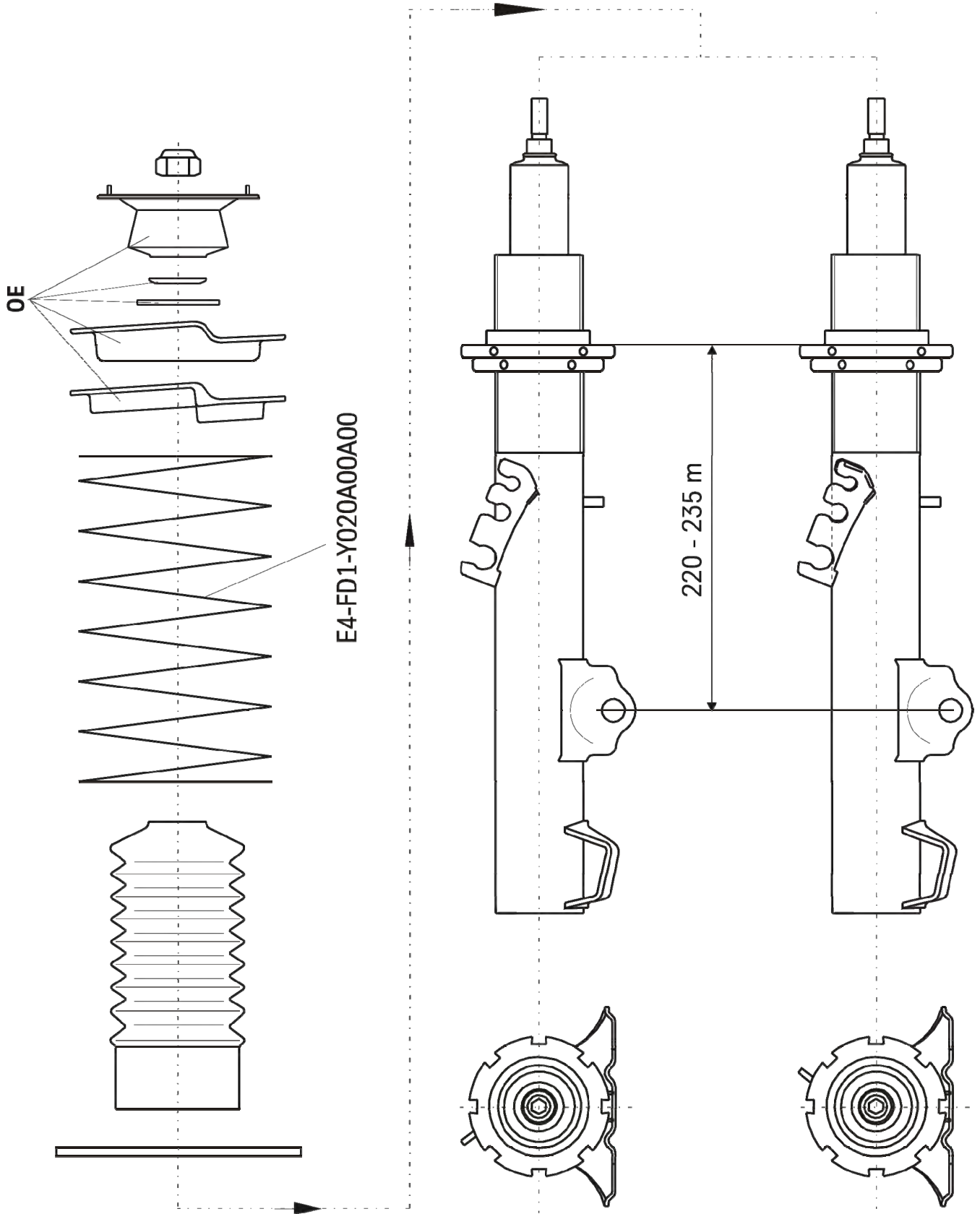

**OE** = Original Anbauteile

**IMPORTANT!**

**Spring plates must not be adjusted outside the ranges specified below!**

Manufacturer	Bayrische Motoren Werke, BMW			
ABE-/ EG- BE- No.	F547	e1*93/81*0015*..	F920	e1*93/81*0016*..
type designation	3C	3/C	3B	3/B
model	E36 sedan + touring		E36 Coupé, Convertible	

<b>FRONT</b>	maximum permissible axle load 930 kg ( 2046 lb)	
spring part number	main spring E4-FD1-Y020B00	
shock absorber part number	VE3-C497, -C498 left, right	
permissible adjustment range	220 – 235 mm* = 15 mm range	
* measurement:	top edge of spring seat down to the center of upper mount screw	

<b>REAR</b>		
spring type	main spring E4-FD1-Y380A00	
shock absorber part number	BE3-C499	
maximum permissible axle load	bis 1070 kg ( 2354 lb)	bis 1130 kg (2486lb)
permissible adjustment area	20 – 30 mm* = 10 mm range	25 – 30 mm* = 5 mm range
* measurement:	top edge of spring seat down to primary spring seat	

- There are no technical objections against the use of all O.E. wheel/ tyre combinations.
- Because of the increased bump travel on axle 1, all special wheel/ tyre combinations which have already been entered ( approved) must be re- examined with regard to freedom of motion. Critical areas are f. e.: area of outer tyre flank above centre of wheel.
- In so far as these wheel-/ tyre combinations are not listed below, the examination must be carried out by an officially recognised expert or test engineer at a TÜV/ TÜH test facility. The vehicle registration document in accordance with §21 German Road Traffic Licensing Code - StVZO must be presented. Any certificates already obtained with regard to special wheel/tyre combinations are invalid if they do not contain a reference to the suspension system described in this document.
- The dynamic ground clearance is decreased by the provision of special springs/ dampers which increase the bump travel of the front and rear axle. In the case of the test vehicle, the **distance from the ground** amounted to **100 mm** under the motor crossbar. Care must be taken when driving over humps, barriers and heightened paving or road surfaces.
- If special spoilers, aprons and exhaust systems are mounted, attention must be paid to the decreased overhang angle ( driving up ramps etc.).
- The specified minimum height of the coupling ball above the road surface with the permissible total weight of the vehicle ( acc. DIN 74058) is 350 mm.

## Remove

Place vehicle on a chassis hoist,  
lift it and remove wheels.



***The lower control arm must be supported by suitable tools***

Remove top and bottom fixing mount.

Remove shock absorber and  
original mounting parts.

## Install

Fit BILSTEIN and/ or original mounting parts on BILSTEIN  
shock absorber in reverse sequence of removal.

Fit BILSTEIN shock absorber to the vehicle  
in reverse sequence of removal.

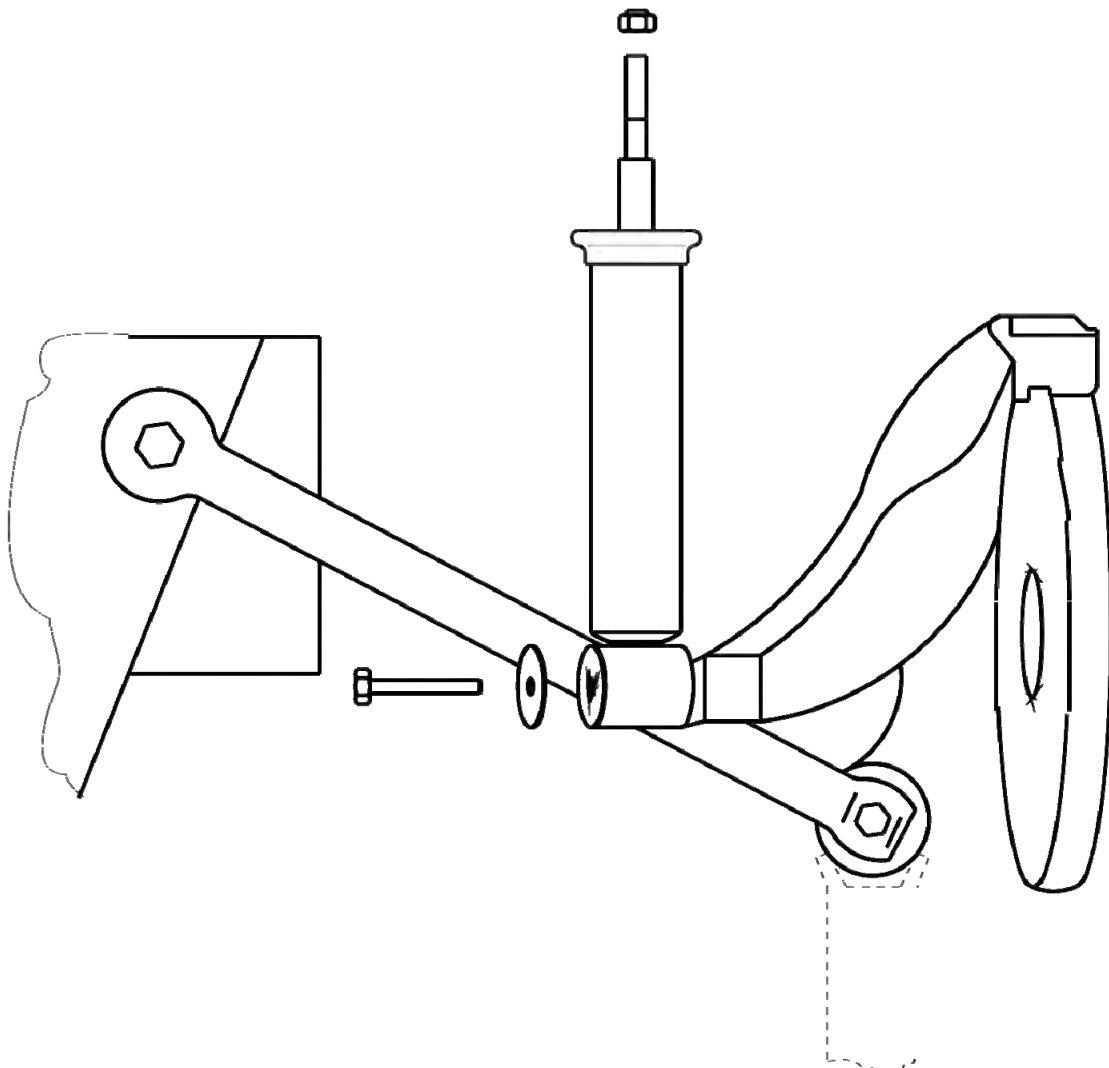

**- mounting instnction for rear axle height adjustment**

E4-FD1-Y380A00

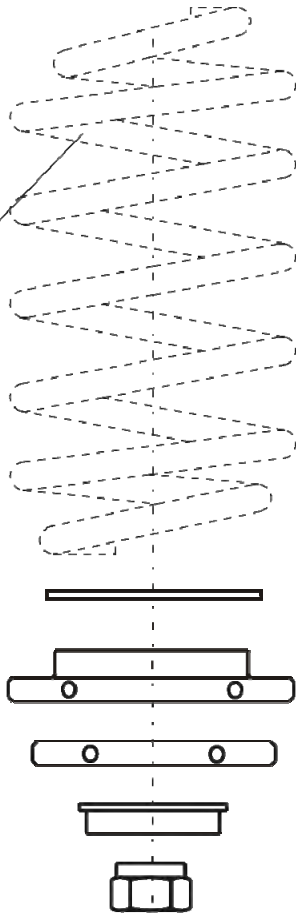

**Ausführung 1/ type 1**  
 ( bei großer Öffnung im Querlenker/  
 for a large hole at transverse control arm )

**Ausführung 2/ type 2**  
 ( bei kleiner Öffnung im Querlenker/  
 for a small hole at transverse control arm )

