



AUDI A3/ S3/ RS3 incl. Sportback, Quattro and convertible PSS10
SEAT Altea PSS10
Seat Leon PSS10
SEAT Toledo PSS10
SKODA Octavia PSS10
SKODA Superb PSS10
VW Golf V + VI PSS10
VW Golf Plus PSS10
VW Golf V + VI 4- motion PSS10
VW Golf V + VI station wagon PSS10
VW Jetta PSS10
VW Passat sedan/ station wagon PSS10
VW Passat CC PSS10
VW Touran PSS10



**Before installation please observe
the following points:**

- Read all information in this manual carefully.
All suspension components are fitted and removed acc. to the manufacturer's specifications for fitting and removing, if not otherwise required in these instructions.
- Check that your vehicle type is listed in the certificate as being released for this kit.
- Check the product for all components before starting installation!
- Check that dimensions and fastening points are comparable between the original and BILSTEIN shock absorbers.
- Directional references (left, right, front, rear) are always with reference to the driving direction.
- The test vehicles are left- hand drive cars.

**After installation please observe
the following points:**

- Set the vehicle height by adjusting spring plates and lock nuts on the new dampers. Only use the supplied spanner wrenches.
- After installing the suspension system, caster and camber must be checked and adjusted according to manufacturer's specifications.
Check and reset load- dependent brake compensator and ABS system according to manufacturer's specifications.
Check and adjust headlight aim.
- Because the vehicle has been lowered, freedom of movement for all wheel-/ tire- combinations must be checked.
- All rubber- mounted strut/ damper attachments must not be fully tightened until AFTER the suspension system is loaded (wheels on the ground). Other mounting fasteners (for example brackets) must be securely tightened BEFORE load is placed on the suspension system.

All diagrams are generalized
and not to scale!
Brackets, etc. specific to
strut are not shown!

instruction for force adjustment

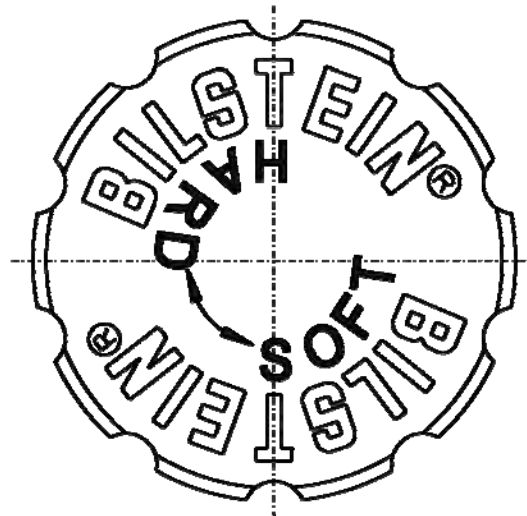
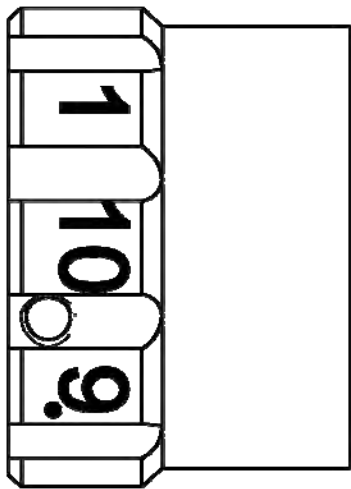

position **1** = **comfort**
 position **10** = **sport**

During the adjustment you will hear a positive „click“ at each position of the adjustment.

Instruction for the front and rear axle

Status of delivery is position **1**.

The adjusting element is located at the bottom edge of the strut.

Position **1** must aligned with the red mark.

Take care that the adjustment position is the same on both sides of vehicle (left/ right).

- list of torques

	M8	M 10	M 12	M 14	M 16	Thread
	13	25	45	72	110	Torque Nm
	10	19	34	54	83	Torque ft lb

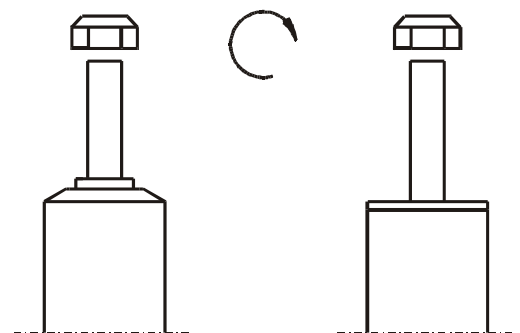

Do not use an impact tool to loosen or tighten fasteners due to possible damage to the product.
Self- locking nuts must only be used once!

Removal

Place vehicle on a wheel-free car hoist, lift it and remove wheels.

Disconnect the negative battery pole.

Vehicles equipped **with xenon headlight** the movable element of sensor for the headlamp levelling controller must remove before.



The lower control arm must be supported by suitable means!

Remove bottom mount.

Remove top fixing nuts from support bearing.

Do not remove centre nut at this time!

Remove complete strut and clamp it in an appropriate strut vice.

Using a suitable spring compressor, compress suspension spring until tension on support bearing is free to move.

Release centre nut and remove original mounting parts and coil spring. Please refer to diagram to identify which parts will be replaced with BILSTEIN- supplied components.

Installing

Assemble BILSTEIN and/ or original mounting parts, as well as the new BILSTEIN spring on the BILSTEIN strut in reverse order as removal.



IMPORTANT! Spring plates must not be adjusted outside the ranges specified below!

The correct mounting position of the suspension springs can be determined by the printing on the springs; install them with the print upright.

Do not reuse original dust cover and original-bumper, since BILSTEIN- strut has built in bump stop.

Fit assembled BILSTEIN strut to the vehicle in reverse order as removal.

Connect the negative battery pole again.

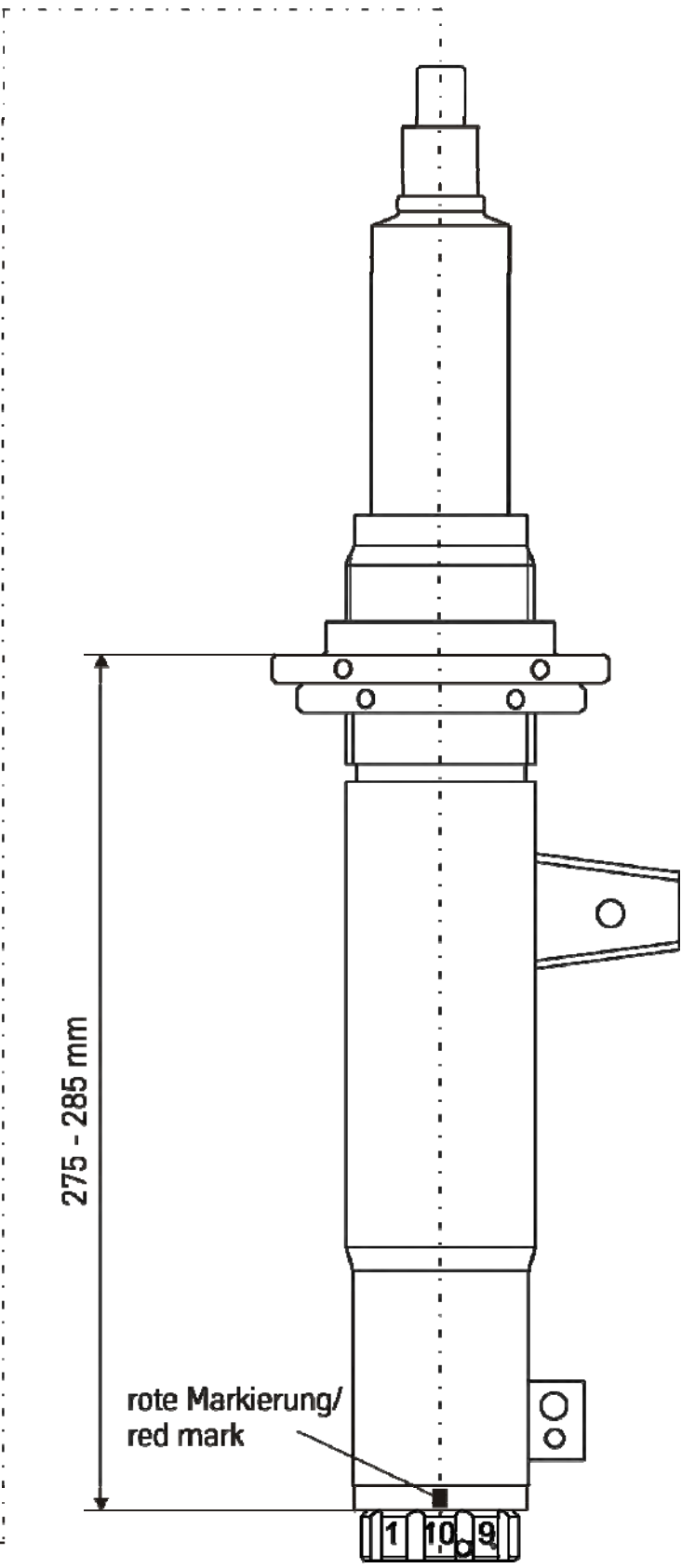
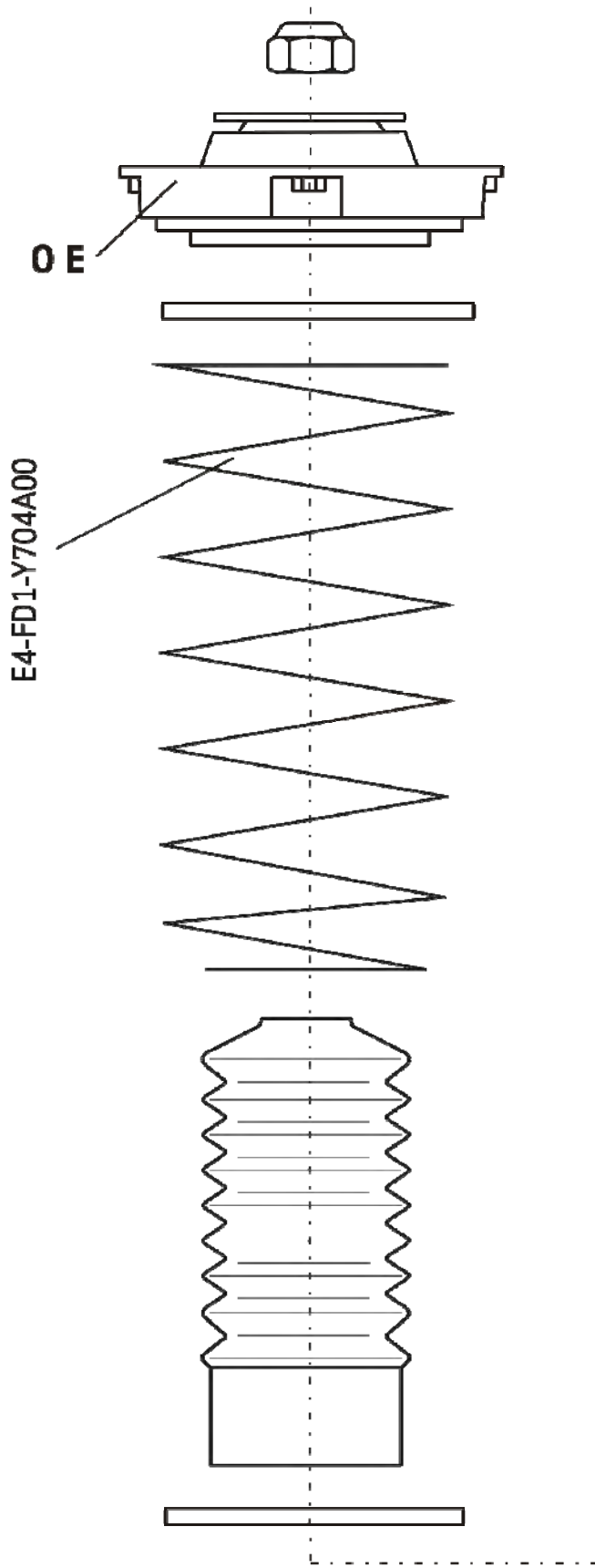

OE = Original Anbauteile
Original Equipment



mounting instruction for rear axle

Removal

Place vehicle on a wheel-free car hoist, lift it and remove wheels.

Disconnect the negative battery pole.



The lower control arm must be supported by suitable means!

Remove top and bottom fixing mount from support bearing.

Remove shock absorber and original mounting parts.

Installing

Fit BILSTEIN and/ or original mounting parts in BILSTEIN shock absorber in reverse order as removal.

Do not reuse original dust cover and original bumper.

Fit BILSTEIN shock absorber to the vehicle in reverse order as removal.

Connect the negative battery pole again.

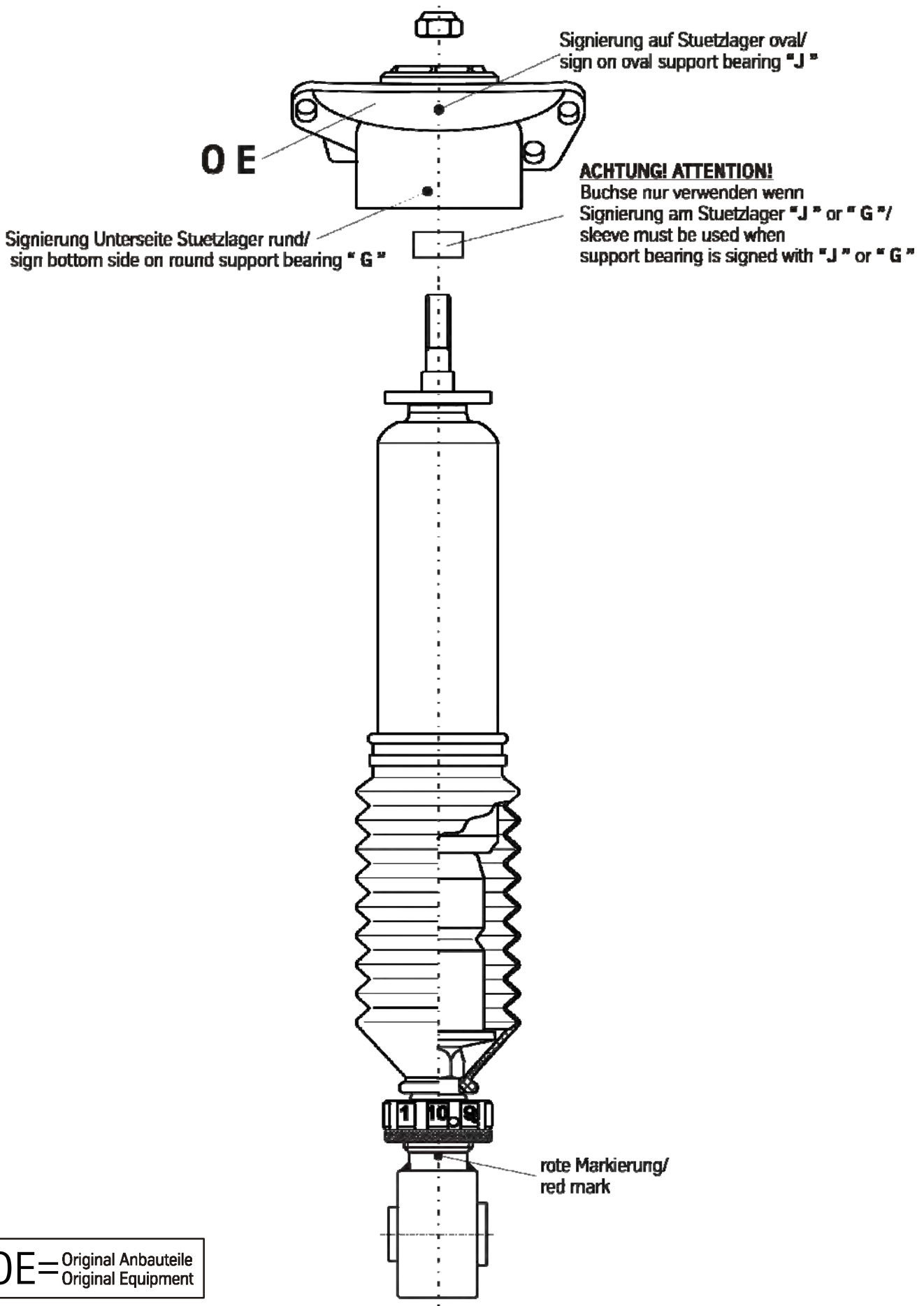

- mounting instruction for rear axle height adjustment

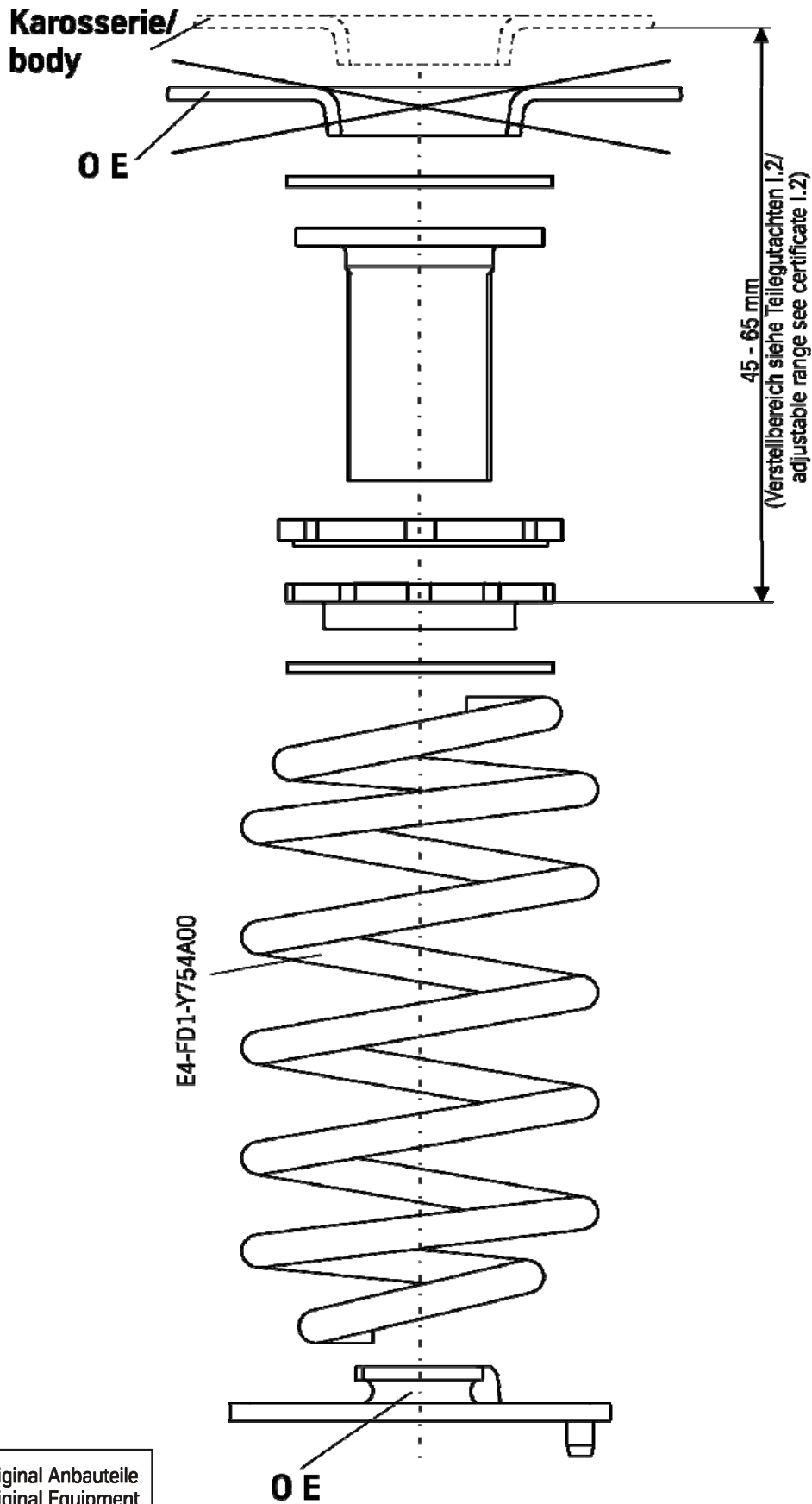

OE = Original Anbauteile
Original Equipment