

position **9** = **comfort** (clockwise direction)
 position **1** = **sport** (counter- clockwise direction)

During the adjustment you will hear a positive „click“ at each position of the adjustment.

Instruction for the front and rear axle

The adjusting element of the front struts is located at the bottom edge of the strut, covered by a blue plastic cap, pos. K (see page 17). That cap must be removed before adjusting. After the adjustment the cap must be replaced again.

- list of torques

	M8	M 10	M 12	M 14	M 16	Thread
	13	25	45	72	110	Torque Nm
	10	19	34	54	83	Torque ft lb

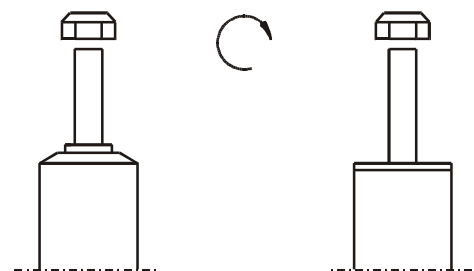

Do not use an impact tool to loosen or tighten fasteners due to possible damage to the product.
Self- locking nuts must only be used once!



**Before installation please observe
the following points:**

- Read all information in this manual carefully.
- All suspension components are fitted and removed acc. to the manufacturer's specifications for fitting and removing, if not otherwise required in these instructions.
- Check that your vehicle type is listed in the certificate as being released for this kit.
- Check the product for all components before starting installation!
- Check that dimensions and fastening points are comparable between the original and Bilstein shock absorbers.
- Remove the negative battery pole.
- Directional references (left, right, front, rear) are always with reference to the driving direction.
- The test vehicles are left- hand drive cars.

**After installation, please observe
the following points:**

- Set the vehicle height by adjusting spring plates and lock nuts on the new dampers. Only use the supplied spanner wrenches.
- All rubber- mounted strut/ damper attachments must not be fully tightened until AFTER the suspension system is loaded (wheels on the ground). Other mounting fasteners (for example brackets) must be securely tightened BEFORE load is placed on the suspension system.
- Because the vehicle has been lowered, freedom of movement for all wheel-/ tire- combinations must be checked.
- Connect the negative battery pole.
- After installing the suspension system, caster and camber must be checked and adjusted according to manufacturer's specifications.
- Check and reset load- dependent brake compensator and ABS system according to manufacturer's specifications.
- Check and adjust headlight aim.

All diagrams are generalized
and not to scale!
Brackets, etc. specific to
strut are not shown!

- mounting instruction for front and rear axle
VE3-C190/ VE3-C191/ VM3-B558/ VM3-C188/ VA3-C202/ VA3-C203

Removal strut

Place vehicle on a chassis hoist, lift it and remove wheels.

Vehicles equipped with xenon headlight the sensor for the headlamp levelling controller must removed before.



The lower control arm must be supported by suitable means!

Remove bottom mount.

Remove top fixing nuts from support bearing.
Do not remove centre nut at this time!

Remove complete strut and clamp it in an appropriate strut vice.

Using a suitable spring compressor, compress suspension spring until tension on support bearing is released.

Release centre nut and remove original mounting parts and coil spring. Please refer to diagram to identify which parts will be replaced with BILSTEIN- supplied components.



Installing strut

Assemble BILSTEIN and/ or original mounting parts, as well as the new BILSTEIN spring on the BILSTEIN strut in reverse sequence of removal.



IMPORTANT! Spring plates must not be adjusted outside the ranges specified below!

The correct mounting position of the suspension springs can be determined by the printing on the springs; install them with the print upright.

Fit assembled BILSTEIN strut to the vehicle in reverse sequence to removal.

The cable for the front electronic force adjustment must be fixed by stick- cable clip (1x) at pos. **A** first. The rubber plug (**G**) must be positioned as shown on the cable and pressed into the designated body cut out (only front). Fix the electronic cable front and rear along the ABS- cable with small cable clips (10x).
(see on page 18/ 19)

All rubber- mounted strut/ damper attachments must not be fully tightened until **AFTER** the suspension system is loaded (wheels on the ground). Other mounting fasteners (for example brackets) must be securely tightened **BEFORE** load is placed on the suspension system. Make sure that the bump stop and dust cover are correctly and properly fastened.

B = BILSTEIN Lieferumfang
Delivered by BILSTEIN

OE = Original Anbauteile
Original Equipment

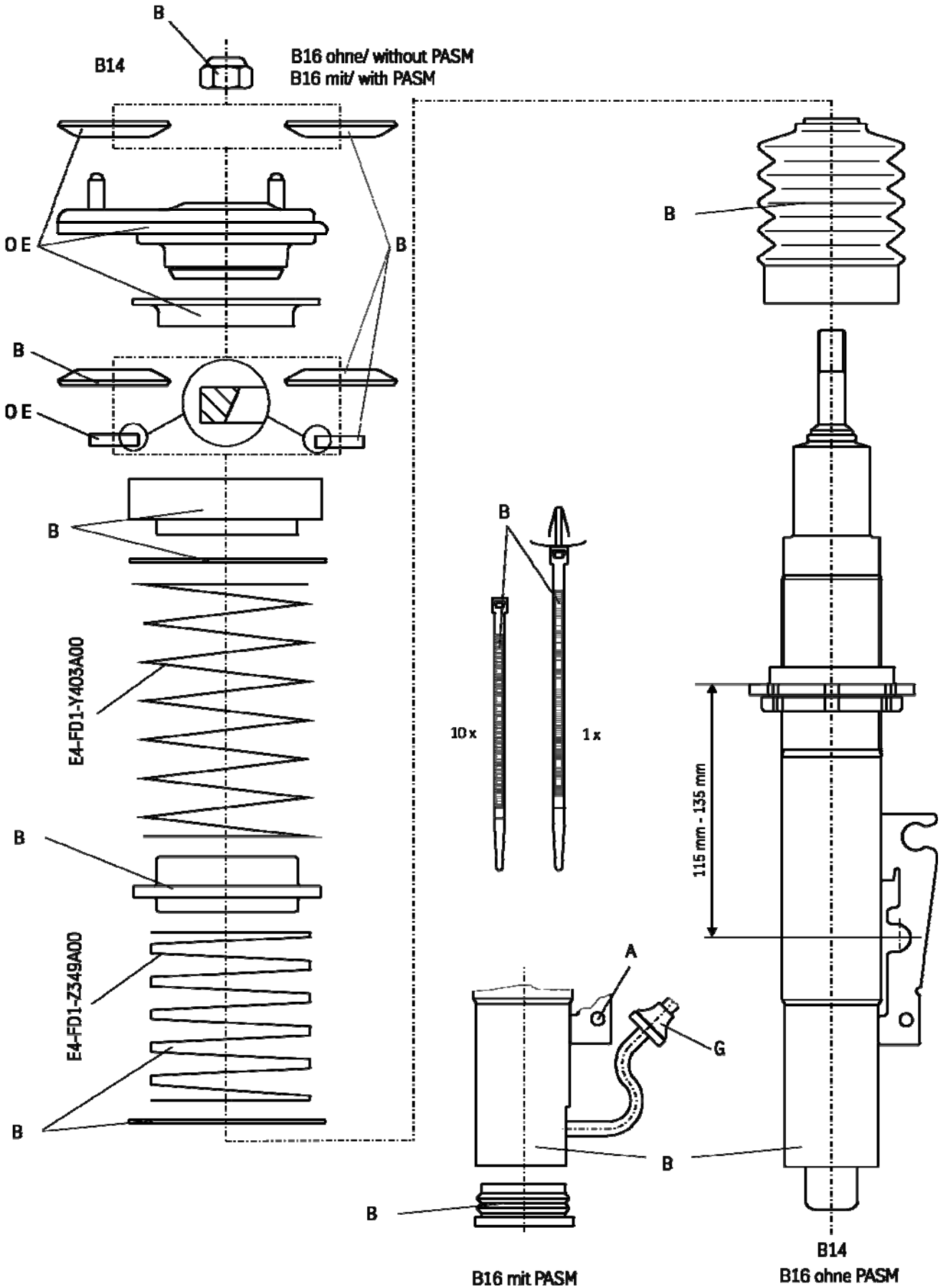

B = BILSTEIN Lieferumfang
Delivered by BILSTEIN

OE = Original Anbauteile
Original Equipment

