

INSTALLATION INSTRUCTIONS.

45-240973 / 45-240980



INSTALLATION INSTRUCTIONS.

BILSTEIN Article No.: 45-240973 / 45-240980

General information:

- Do not store struts below -15°C or above +50°C
- Disassembly and installation may only be performed by fully qualified and certified personnel at a specialist workshop
- Special car manufacturer's tools and equipment are required for replacement work!
- Check air pipes and cables – renew if damaged
- Caution! The vehicle and the air suspension module may be damaged if replacement work is not carried out according to the instructions or in a different order
- BILSTEIN shock absorbers may only be replaced as a set
- Air springs are left and right-hand parts

Dismantling the rear strut



The ignition must remain switched off during work on the air suspension module.

- Raise vehicle

Use the chassis lifting points prescribed by the car manufacturer.



Risk of serious bodily injury or death due to the vehicle slipping.

- Remove wheel
- Vent air from strut with OBD system
- Unscrew pressure line on upper end of suspension strut ①



- Secure residual pressure valve when loosening



Do not twist, fold or crimp air line.

- Seal line with plug during work
- Disconnect the plug-in connection ②

②



- Unscrew screw connections of the spring strut ③

③



- Loosen screw connection on spring strut ④

④



- Remove strut from below

Installing the rear strut



Fully tighten all movable, suspension-related screw connections only when the vehicle is in ready-to-drive condition, observing the manufacturer's specifications and tightening torques. Caution! Original part may still be pressurised. Loosen residual pressure valve slowly and allow any air to escape.

- Unscrew bearing support **5** from the original part and install on the BILSTEIN spring strut



- Insert cable adapter **6** in the parallel damping adjustment unit of the BILSTEIN spring strut and fasten to the welding stud on the shock absorber using the enclosed cable clip **7**

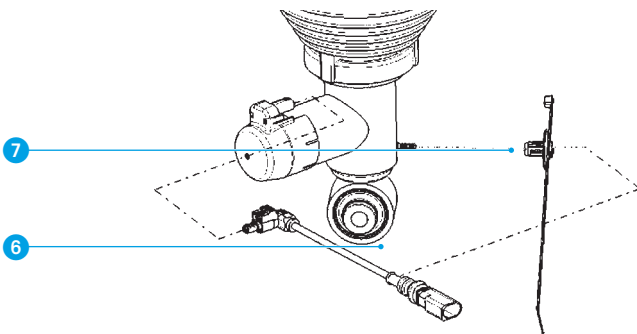

- Fasten the line that leads to the plug to the side of the welding stud on the BILSTEIN spring strut with the other enclosed cable clip
- Fasten the line that leads to the plug to the side of the welding stud on the BILSTEIN spring strut with the other enclosed cable clip.
- Replace self-locking nuts.
- Reassemble the BILSTEIN strut in reverse order of disassembly.
- Detach pressure line connector from BILSTEIN air suspension module; do not remove the plastic plug in advance



- If necessary, replace old pressure line connector with new parts, ensuring correct installation of cone ring (cone pointing towards the line)



Never completely lower the vehicle from the lifting platform with unpressurised air suspension.

- Connect the OBD system and start ignition
- Fill air spring strut using OBD System
- Check air suspension system for leaks
- Lower vehicle from lifting platform
- Fully tighten screw connections loosened during replacement work in accordance with the car manufacturer's specifications

Note: Manufacturer shall not be liable for any injury, loss or damage resulting from any improper alteration, disassembly, handling, installation, service, repair or use of this product, including but not limited to the failure to follow the foregoing instructions. Improper alteration, disassembly, handling, installation, service, repair or use of this product will void the product warranty.