

E4-WM5-Y314A00 MOUNTING INSTRUCTION

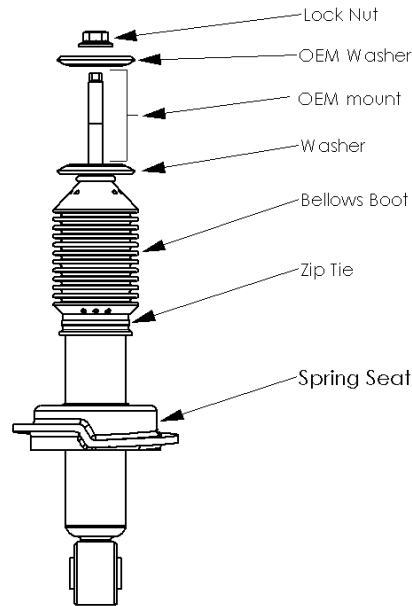

IMPORTANT!

Installation of shock absorbers requires special tools and expert knowledge. Accordingly, installation of all BILSTEIN products must be performed by a qualified specialist.

Always use a chassis hoist for the installation of BILSTEIN products and make certain that the raised vehicle is securely attached to the hoist and/or supported to prevent the vehicle from slipping, falling, or moving during the installation process.

If you choose to install any BILSTEIN product without the necessary special tools, expertise or chassis hoist, you may subject yourself to the risk of seriously bodily injury or death. If you elect not to use a chassis hoist, at least make sure the vehicle is on level ground, that all tires on the ground during installation are blocked to prevent movement, and that adequately secured safety stands (jacks stands) are used to support the chassis. **NEVER** get under the vehicle until you have checked to make sure all of these steps are preformed.

Instructions for assembly of shock absorber module:

1. Rotate spring seat so that step faces outside of the vehicle.
2. Place washer directly above the bellows boot as shown in the above diagram.
3. Install coil spring and original upper mount.
4. Place a second washer over the original upper mount as shown in the above diagram.
5. Install new lock nut and tighten to 54 Nm (40 lb./ft).