

E4-WM5-Y489A00 MOUNTING INSTRUCTION



For 5100 Series:

24-249928 – FRONT

33-247724 – LEFT REAR

33-247717 – RIGHT REAR

IMPORTANT:

PLACE CIRCLIP IN APPROPRIATE GROOVE TO ADJUST RIDE HEIGHT.

Use appropriate tools to move the circlip. Ensure that the circlip is fully seated in the groove after moving it (you should be able to rotate it manually in the groove). Install the spring seat in the direction shown only. The circlip must fit completely in the groove inside spring seat (A). **Improper installation will cause permanent damage to the shock!**

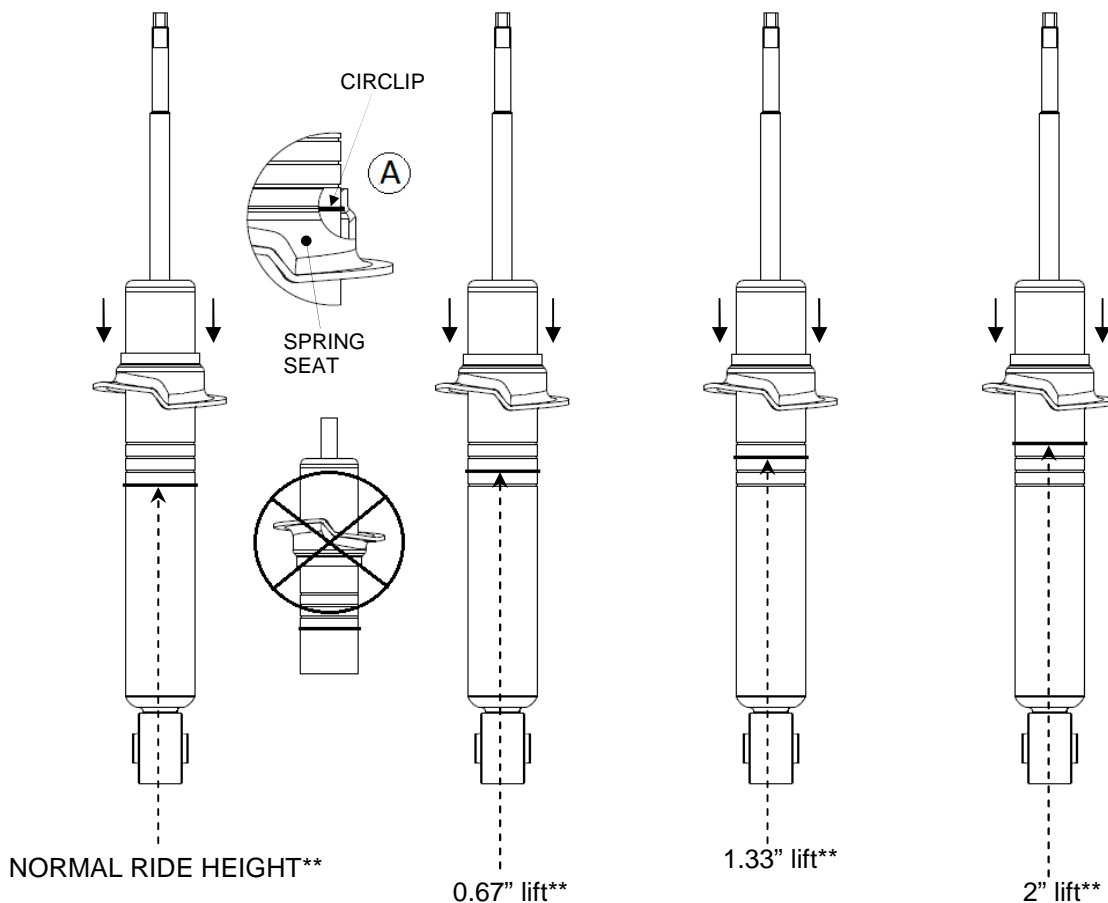

** Ride heights indicated are typical. Actual ride height is influenced by which factory suspension the vehicle is equipped with and its condition; optional equipment and accessories on your vehicle, and other vehicle modifications such as replacement coil springs, wheel and tire combinations, etc.

Modifying/lifting the suspension to your vehicle may raise its center of gravity and may make it more susceptible to loss of control and/or rollover, which may result in death or serious injury. We strongly recommend that you offset the loss of rollover resistance as much as possible by increasing tire track width, and that you equip the vehicle with a functional roll bar and cage system.

Wear seat belts and shoulder harnesses at all times, and avoid situations where a side rollover may occur.

E4-WM5-Y489A00

MOUNTING INSTRUCTION



IMPORTANT!

Installation of shock absorbers requires special tools and expert knowledge. Accordingly, installation of all BILSTEIN products must be performed by a qualified suspension specialist.

Always use a chassis hoist for the installation of BILSTEIN products and make certain that the raised vehicle is securely attached to the hoist and/or supported to prevent the vehicle from slipping, falling, or moving during the installation process.

If you choose to install any BILSTEIN product without the necessary special tools, expertise or chassis hoist, you may subject yourself to the risk of serious bodily injury or death. If you elect not to use a chassis hoist, at least make sure the vehicle is on level ground, that all tires on the ground during installation are blocked to prevent movement, and that adequately secured safety stands (jack stands) are used to support the chassis. **NEVER** get under the vehicle until you have checked to make sure all of these steps are performed.

CAUTION!!

Before disassembling the front suspension, refer to the vehicle manufacturer's Service Manual for proper procedures. The coil spring is preloaded and must be compressed with a spring compressor to release load before the upper mount is disassembled. Failure to follow the vehicle manufacturer's procedures may cause serious injury or death, and may damage the vehicle.

Instructions for assembly of front shock absorber module:

1. Install the spring seat onto the shock body as shown. Ensure that the groove inside the spring seat fits over the circlip on the shock body. The dust boot and boot adapter will need to be removed to slide the spring seat on.
2. Re-install the dust boot and boot adapter onto the stem of the rod as shown. The boot adapter is clipped into the top of the dust boot. Install OE coil spring and re-install all original mount parts in reverse order of removal in accordance with the vehicle manufacturer's Service Manual. Please refer to Figure 1 for the proper order of installation of the module components.
3. Install new lock nut and tighten until it bottoms out. Torque lock nut to vehicle manufacturer's service manual torque specification.

*****Only continue with Steps 4 and 5 if you are using the highest ride height setting*****

4. Remove original chassis jounce bumpers (two per side) according to vehicle manufacturer's procedures.
5. Install the new spacer washers as shown and reinstall the jounce bumpers in their original positions. Torque to 27 Nm (20 lb-ft).



E4-WM5-Y489A00 MOUNTING INSTRUCTION

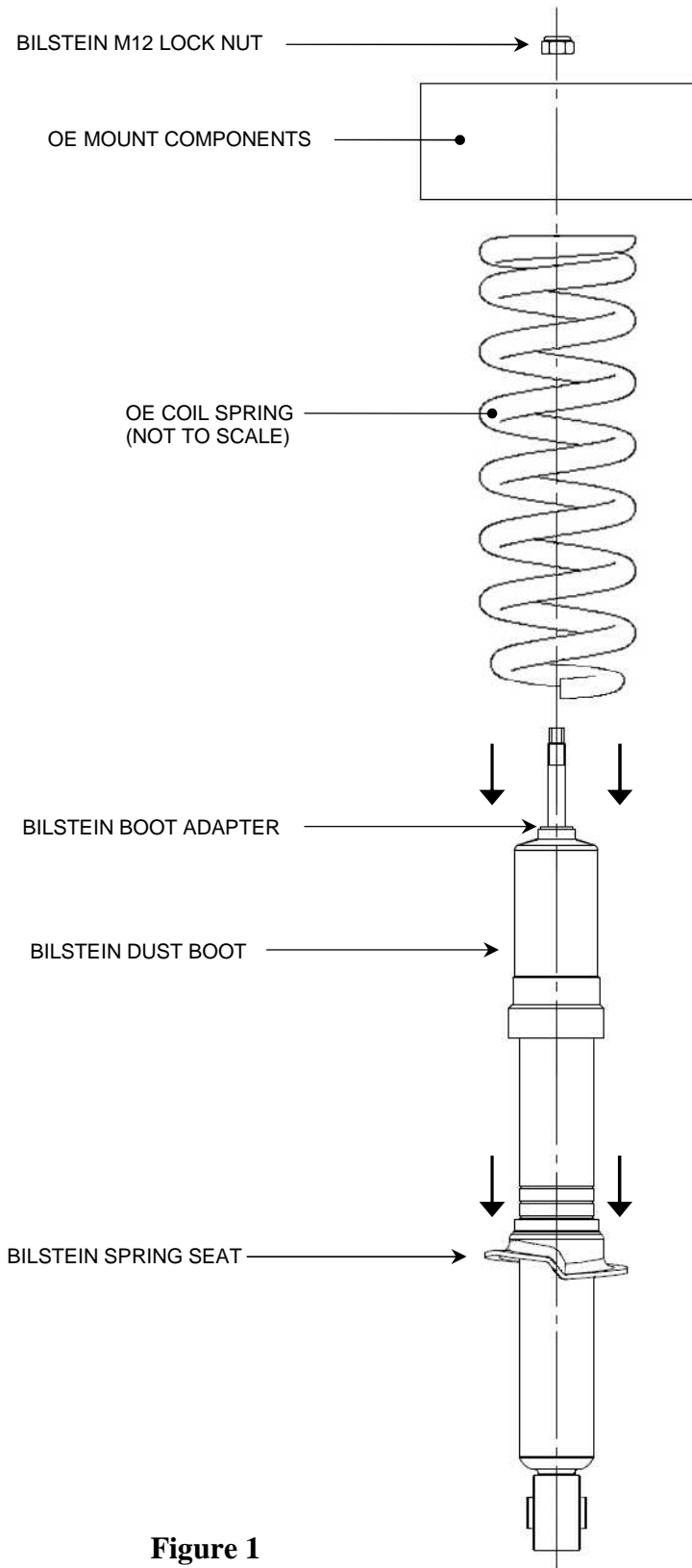

Figure 1

E4-WM5-Y489A00

MOUNTING INSTRUCTION



Rear Shock Installation Procedure:

Note: Due to the increased collapsed length of Bilstein Shock Absorbers 33-247724 and 33-247717, a 1" block lift is required.

- A. Remove the existing shocks from the vehicle following all procedures in the vehicle manufacturer's service manual. The Bilstein Shock Absorber is installed in the same manner as the OE shock, except with the shock body oriented upwards.
- B. The left and right rear shocks are different lengths and need to be installed as follows:
33-247724 – LEFT REAR
33-247717 – RIGHT REAR
- C. Install the Bilstein Shock Absorber in the original location with the new supplied eye ring bushings and attach the upper and lower mounts. Please refer to Figure 2 for the correct orientation of the eye-ring bushings.
- D. Be sure to lower the vehicle such that its full weight is on the suspension prior to fully tightening the fasteners.
- E. Tighten the upper and lower mount fasteners to the vehicle manufacturer's service manual torque specification.

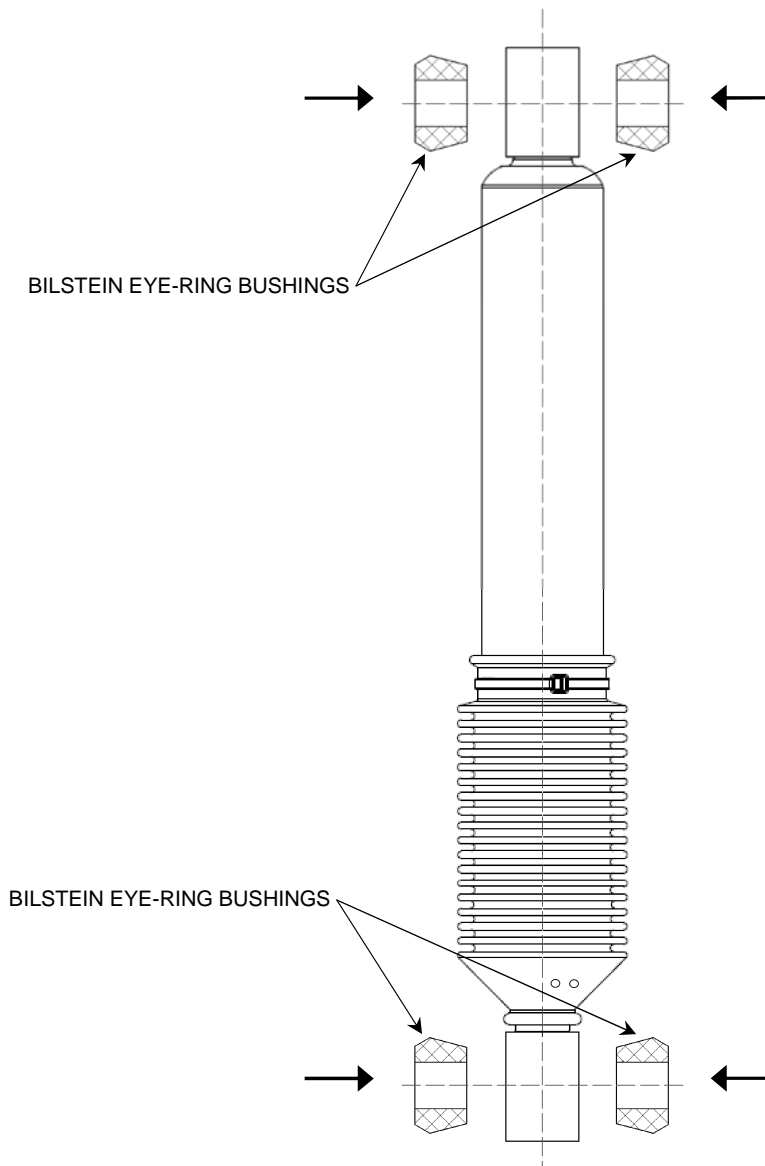

Figure 2