

MOUNTING INSTRUCTION E4-WM5-Y133A00

1. nut torque 11 ft lb *B
2. washer
3. nut torque 16 ft lb
4. support bearing
5. rubber pad
6. helical spring
7. rubber pad
8. cap
9. bumper
10. dust cover
11. top cap *B
12. BILSTEIN shock absorber
13. spring plate *B
14. spring ring
15. hexagon bolt torque 93 ft lb

*B =
mounting parts delivered by BILSTEIN

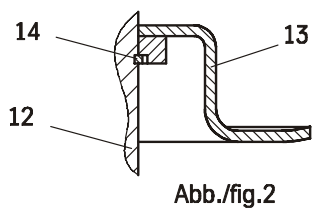
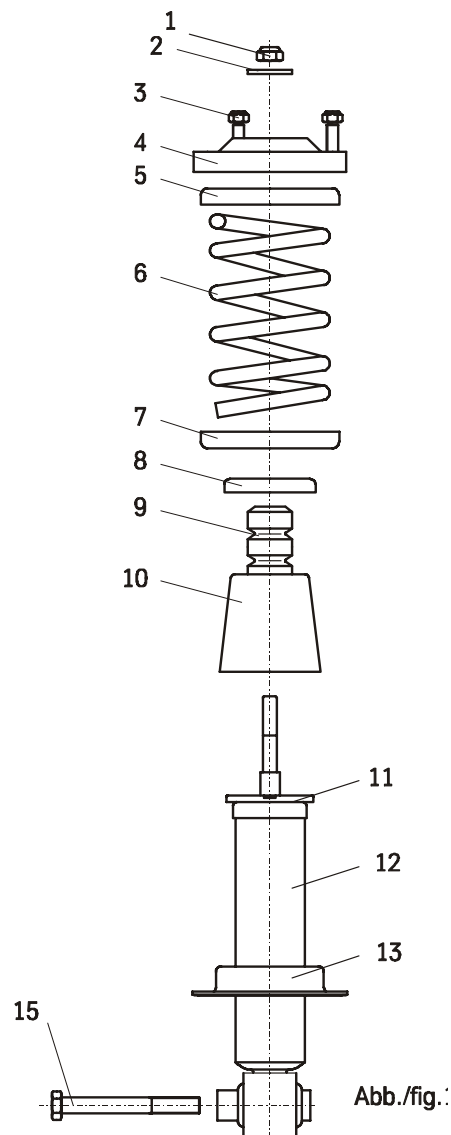

ATTENTION!
When fitting the spring plate (13) care must be taken to ensure that the spring ring (14) is seated correctly!

ATTENTION!
Do not damage the piston rod when knocking the cap (11)!

