

E4-WM5-Y184A00

MOUNTING INSTRUCTIONS

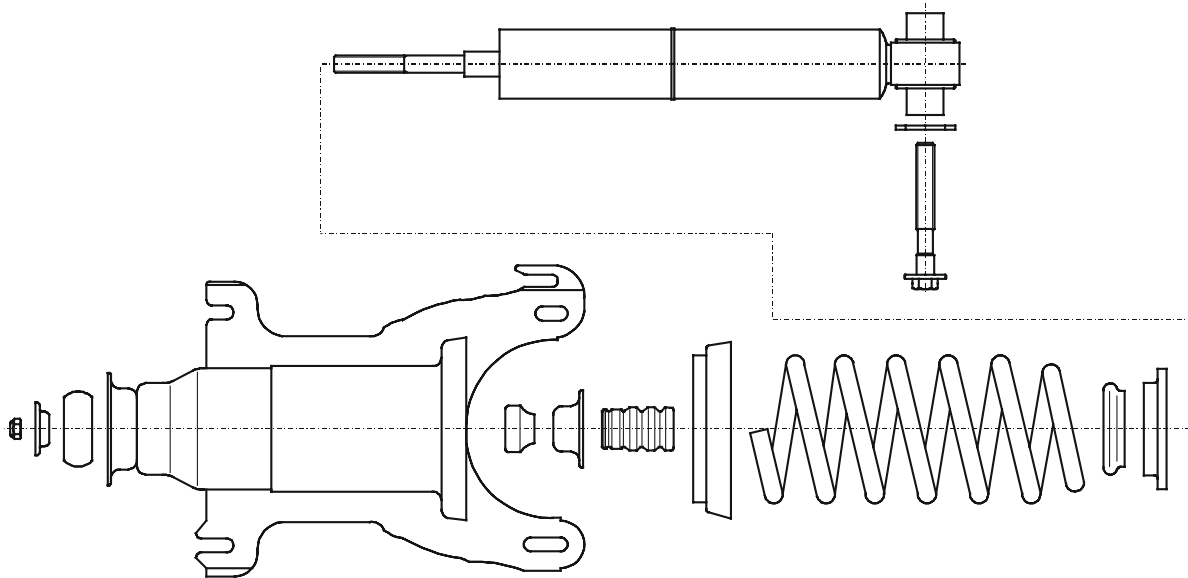

**ALL DRAWINGS ARE
GENERALIZED!
BRACKETS, ETC. SPECIFIC
TO STRUT ARE NOT SHOWN!**



When fitting the spring plate (1) care must be taken to ensure that the circlip ring (2) is seated correctly!

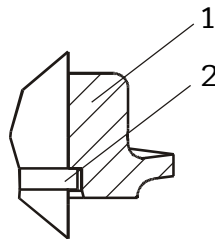

Fitting of plates with chamfer (if exist)

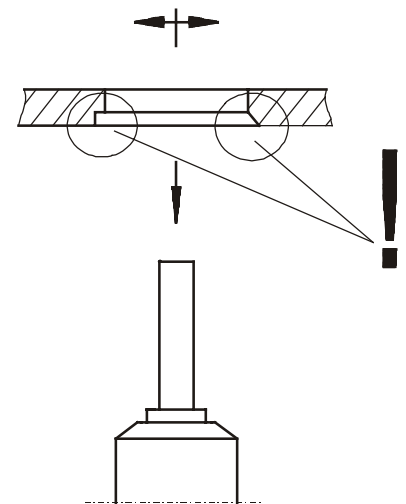

Do not damage the piston rod when knocking a top cap (6)!

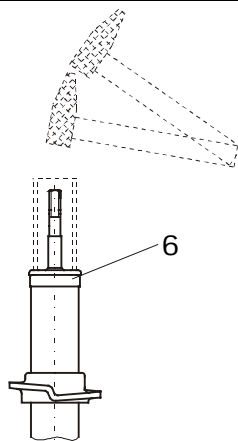

List

	M8	M 10	M 12	M 14	M 16
	13	25	45	72	110
	10	19	34	54	83

Thread

Torque
Nm

Torque
ft lb

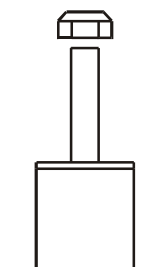
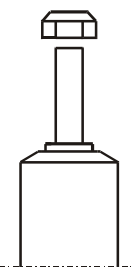

E4-WM5-Y184A00

MOUNTING INSTRUCTIONS



1. BILSTEIN shock absorber with original spring
2. BILSTEIN shock absorber with BILSTEIN spring
3. Original shock absorber with BILSTEIN spring

Remove

Place vehicle on a chassis hoist,
lift it and remove wheel



The lower control arm must be supported by suitable means!

Remove bottom mount.

Remove top fixing nuts from support bearing.
Do not remove center nut at this time!

Remove complete shock absorber and
clamp it in an appropriate strut vise.

Compress suspension spring until tension on support bearing is released.

Release center nut and remove original mounting parts. Please refer to diagram to identify which parts will be replaced with BILSTEIN- supplied components.

Install

Fit the spring plate supplied to the BILSTEIN shock absorber (page 1).
(Not necessary for original shock absorber!)

Assemble BILSTEIN and/ or original mounting parts on BILSTEIN shock absorber in reverse sequence of removal.



Before releasing the spring, care is to be taken to ensure that the ends of the spring rest in the cutouts of the top and bottom springpads.

Fit assembled shock absorber to the vehicle in reverse sequence of removal.

All rubber- mounted strut/ damper attachments must not be fully tightened until AFTER the suspension system is loaded (wheels on the ground). Other mounting fasteners (for example brackets) must be securely tightened BEFORE load is placed on the suspension system.