

E4-WM5-Y300A00

MOUNTING INSTRUCTION



- list of torques

	M8	M 10	M 12	M 14	M 16	Thread
	13	25	45	72	110	Torque Nm
	10	19	34	54	83	Torque ft lb

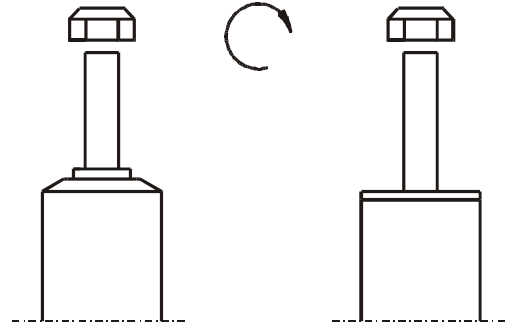

FOR THE REMOVAL AND INSTALLATION OF NUTS, IMPACT TOOLS MUST NOT BE USED BECAUSE THIS WOULD DAMAGE THE MOUNT THREADS. SELF- LOCKING NUTS MUST ONLY BE **USED ONCE!**

All rubber- mounted strut/ damper attachments must not be fully tightened until AFTER the suspension system is loaded (wheels on the ground). Other mounting fasteners (for example brackets) must be securely tight-ened BEFORE load is placed on the suspension system.

ALL DIAGRAMS ARE GENERALIZED AND NOT TO SCALE! BRACKETS, ETC. SPECIFIC TO STRUT ARE NOT SHOWN!

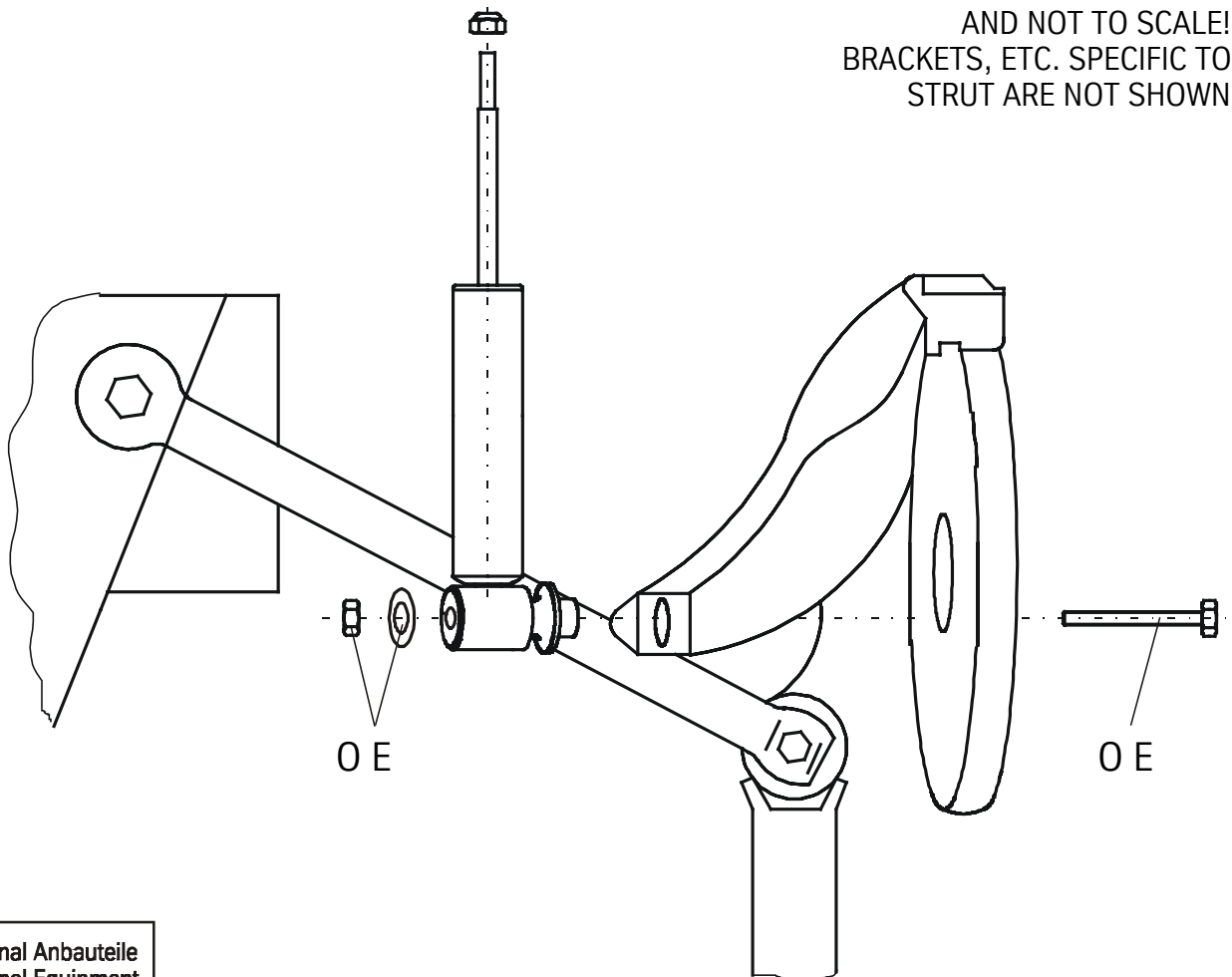

OE = Original Anbauteile
Original Equipment

E4-WM5-Y300A00

MOUNTING INSTRUCTION



1. BILSTEIN shock absorber with original spring
2. BILSTEIN shock absorber with BILSTEIN spring
3. Original shock absorber with BILSTEIN spring

Removal

Place vehicle on a chassis hoist, lift it and remove wheels.

Vehicles equipped **with xenon headlight** the sensor for the headlamp levelling controller must be removed before.



The lower control arm must be supported by suitable means!

Remove bottom mount.

Remove top fixing nuts from support bearing. Do not remove center nut at this time!

Remove complete shock absorber and clamp it in an appropriate strut vise.

Using a suitable spring compressor, compress suspension spring until tension on support bearing is released.

Release center nut and remove original mounting parts and coil spring. Please refer to diagram to identify which parts will be replaced with BILSTEIN-supplied components.

Install

Assemble BILSTEIN and/ or original mounting parts, as well as the new BILSTEIN spring on the BILSTEIN shock absorber in reverse sequence of removal.



Before releasing the spring, care is to be taken to ensure that the spring rests in the cutouts of top and bottom spring plate!

The correct mounting position of the suspension springs can be determined by the printing on the springs; install them with the print upright.

Fit assembled BILSTEIN shock absorber to the vehicle in reverse sequence of removal.