

E4-WM5-Y237A00

MOUNTING INSTRUCTION



Before installation please observe the following points:

- Read all information in this manual carefully.
All suspension components are fitted and removed acc. to the manufacturer's specifications for fitting and removing, if not otherwise required in these instructions.
- Check the product for all components before starting installation!
- Check that dimensions and fastening points are comparable between the original and Bilstein shock absorbers.
Remove the negative battery pole.
- Directional references (left, right, front, rear) are always with reference to the driving direction.
The test vehicles are left- hand drive cars.
- The spring seat height for the BILSTEIN shock absorbers/ struts must be taken from the original spring seats before removal.

After installation please observe the following points:

- After installing the suspension system, caster and camber must be checked and adjusted according to manufacturer's specifications.
Check and reset load- dependent brake compensator and ABS system according to manufacturer's specifications.
Check and adjust headlight aim.
- The freedom of movement for all wheel-/ tire- combinations must be checked.
- All rubber- mounted strut/ damper attachments must not be fully tightened until AFTER the suspension system is loaded (wheels on the ground). Other mounting fasteners (for example brackets) must be securely tightened BEFORE load is placed on the suspension system.
Connect the negative battery pole.

E4-WM5-Y237A00

MOUNTING INSTRUCTION



list of torques

	M 8	M 10	M 12	M 14	M 16	Thread
	13	25	45	72	110	Torque Nm
	10	19	34	54	83	Torque ft lb

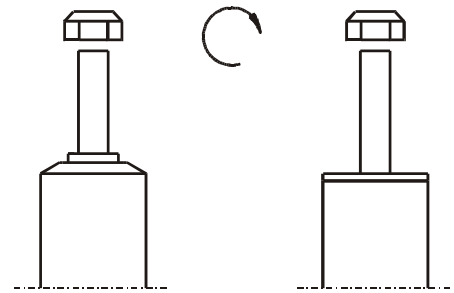

Do not use an impact tool to loosen or tighten fasteners due to possible damage to the product.
Self- locking nuts must only be used once!

All diagrams are generalized and not to scale!
brackets, etc. specific to strut are not shown!



1. BILSTEIN shock absorber with original spring
2. BILSTEIN shock absorber with BILSTEIN spring
3. Original shock absorber with BILSTEIN spring

- mounting instruction for front axle left/ right

Removal strut

Place vehicle on a chassis hoist, lift it and remove wheels.

Vehicles equipped with xenon headlight the sensor for the headlamp levelling controller must removed before.



The lower control arm must be supported by suitable means!

Remove bottom mount.

Remove top fixing nuts from support bearing.
Do not remove centre nut at this time!

Remove complete strut and clamp it in an appropriate strut vice.

Using a suitable spring compressor, compress suspension spring until tension on support bearing is released.

Release centre nut and remove original mounting parts and coil spring. Please refer to diagram to identify which parts will be replaced with BILSTEIN- supplied components.

Installing strut

Do not reuse original- bumper and dust cover, since BILSTEIN- strut has built in bump stop.

Assemble BILSTEIN and/ or original mounting parts, on the BILSTEIN strut in reverse sequence of removal.



IMPORTANT! Spring plates must not be adjusted outside the ranges specified below!

Fit assembled BILSTEIN strut to the vehicle in reverse sequence to removal.

E4-WM5-Y237A00 MOUNTING INSTRUCTION



Vorderachse links/ rechts

front axle left/ right

B= BILSTEIN Lieferumfang
Delivered by BILSTEIN

OE= Original Anbauteile
Original Equipment

X= Sportfeder
competition spring

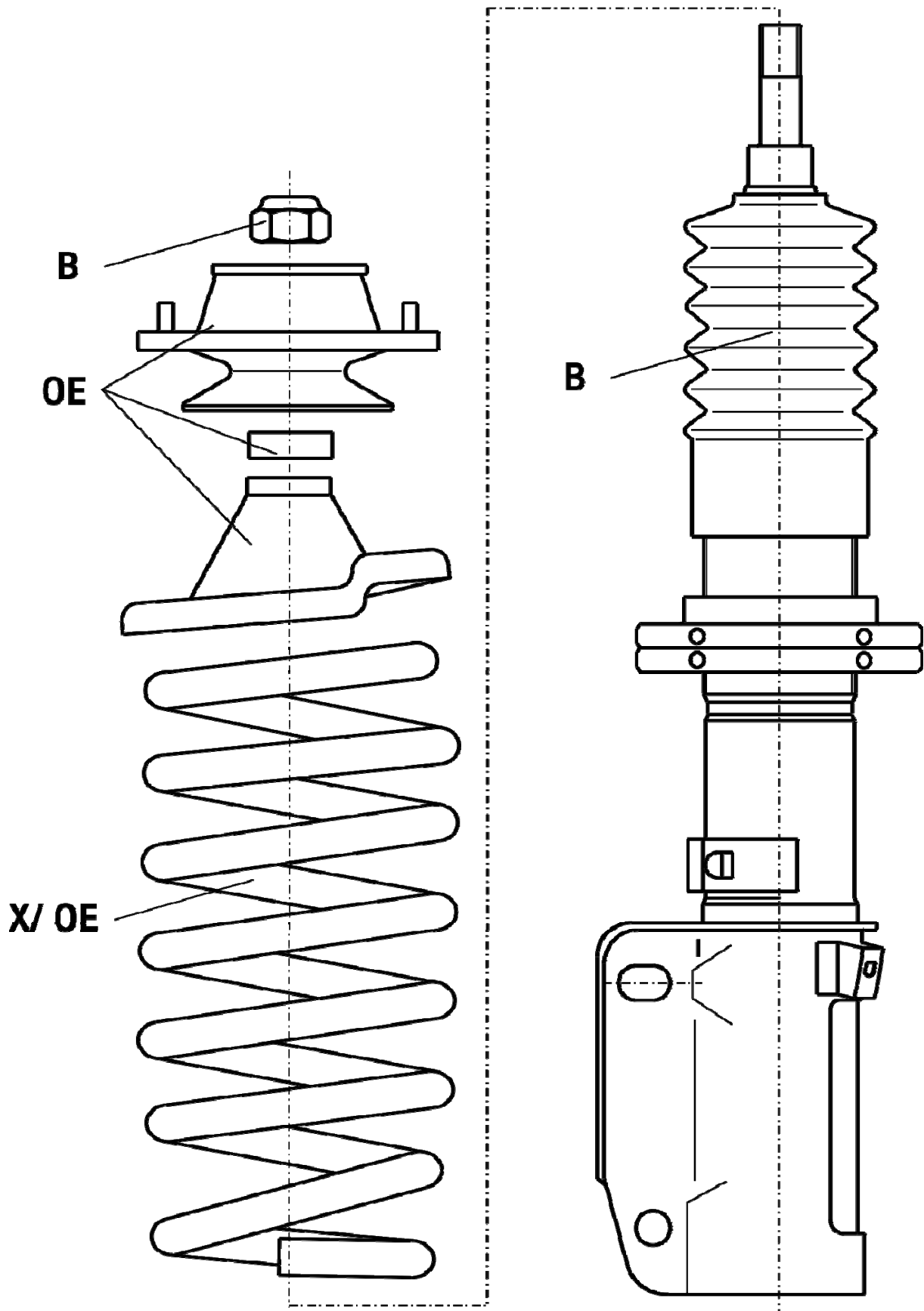

Removal shock absorber

Place vehicle on a chassis hoist, lift it and remove wheels.



The lower control arm must be supported by suitable means!

Remove bottom mount.

Remove top fixing nuts from support bearing.
Do not remove centre nut at this time!

Remove complete strut and clamp it in an appropriate strut vice.

Using a suitable spring compressor, compress suspension spring until tension on support bearing is released.

Release centre nut and remove original mounting parts and coil spring. Please refer to diagram to identify which parts will be replaced with BILSTEIN- supplied components.

NOTE:

Remove original stabi link and replace with parts delivered by BILSTEIN. Positioning of the threaded stabi link joint (**G**) is done by loosening the lock nut (**K**) and adjusting to the appropriate angle for left-hand and right-hand assembly situation (**see fig. on page 6/ 7**).

Installing shock absorber

Do not reuse original- bumper and dust cover, since BILSTEIN- strut has built in bump stop.

Assemble BILSTEIN and/ or original mounting parts, on the BILSTEIN strut in reverse sequence of removal.



IMPORTANT! Spring plates must not be adjusted outside the ranges specified below!

Fit assembled BILSTEIN strut to the vehicle in reverse sequence to removal.

E4-WM5-Y237A00
MOUNTING INSTRUCTION



Gelenkbockposition
links/ left

position of threaded stabi link joint
rechts/ right

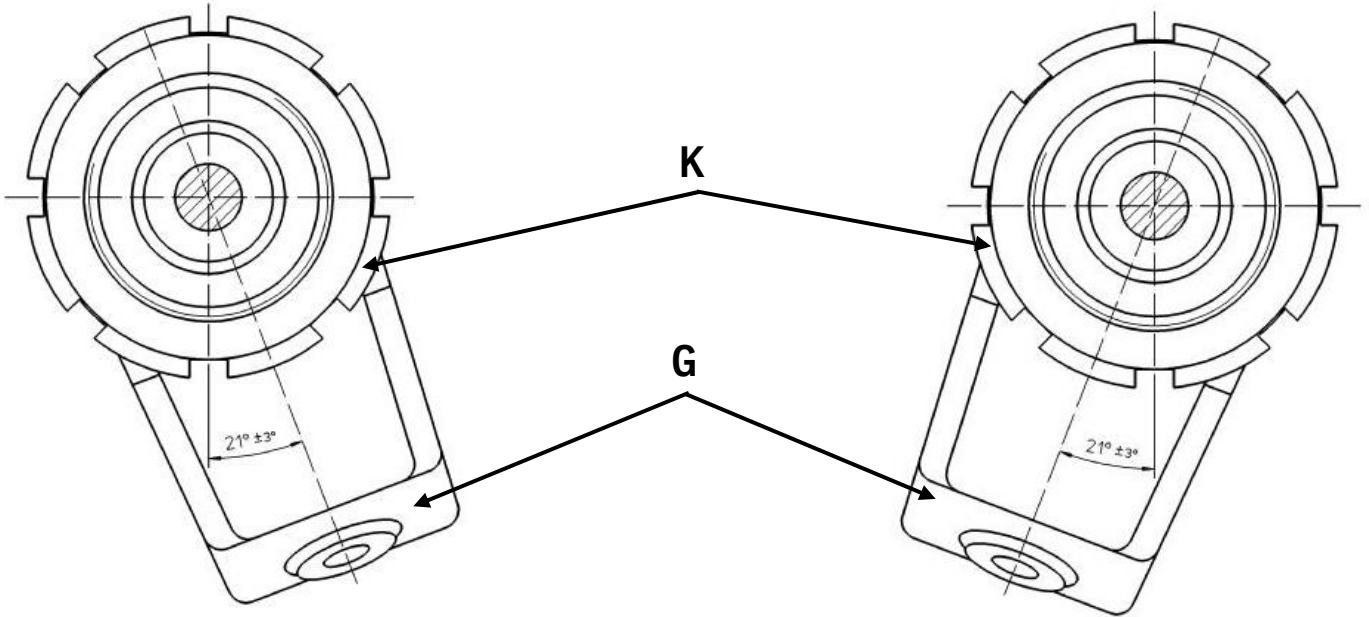

E4-WM5-Y237A00

MOUNTING INSTRUCTION



rear axle

B= BILSTEIN Lieferumfang
Delivered by BILSTEIN

OE= Original Anbauteile
Original Equipment

X= Sportfeder
competition spring

