

E4-WM5-Y525A00 MOUNTING INSTRUCTION



RAM 2500/3500 4WD B8 5100 (Dual Steering Damper Kit)

The installation of these steering dampers must be performed only by experienced and qualified personnel. Read and follow the installation instructions carefully and completely. Incorrect installation will cause damage to the stabilizer and/or the vehicle and could cause serious injury or death. Damage due to improper installation is not covered by the warranty.

Included in this kit are 2 Bilstein steering dampers and a mounting parts kit. One steering damper is mounted in the same location as the OE steering damper. The second steering damper utilizes the same bracket on the axle for one end and uses a billet aluminum bracket that attaches to the tie rod for the other end.

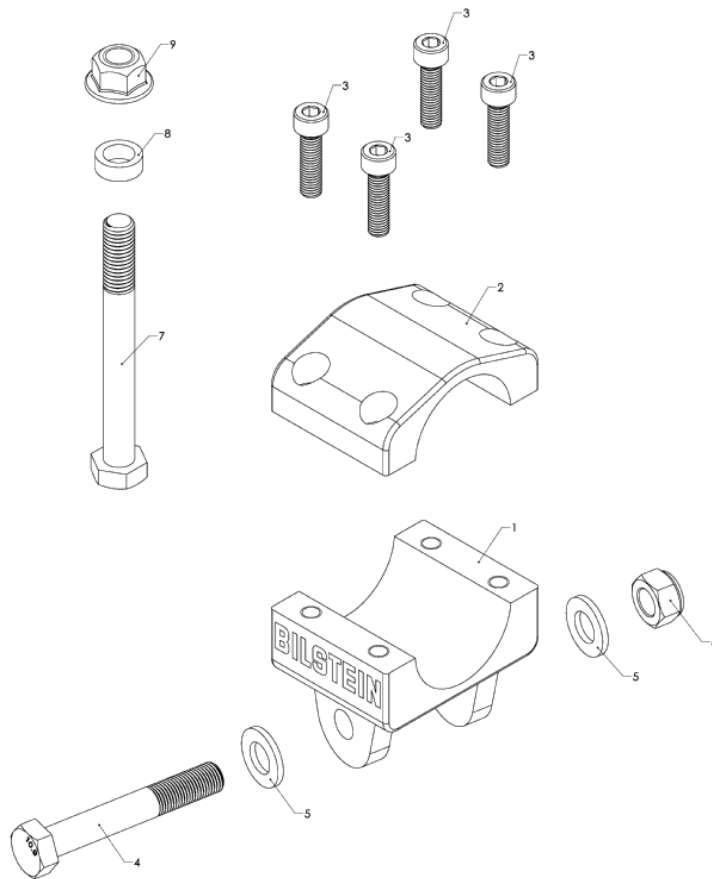

Bill of Materials		
Item #	Description	Qty
1	Lower mounting bracket	1
2	Upper mounting bracket	1
3	Socket Head Cap Screw, M8x1.25, L=30mm	4
4	Hex Head Cap Screw, M12x1.25, L=80mm	1
5	WASHER, 12mm	2
6	Nylock Nut, M12x1.25	1
7	Hex Head Cap Screw, M12x1.75, L=110mm	1
8	Spacer, 12.1mm ID, L=6.5mm	1
9	Flange Locknut, M12x1.75	1

E4-WM5-Y525A00

MOUNTING INSTRUCTION



Before starting the installation procedure, the vehicle must be on level ground with the front wheels straight. It is very important that the front wheels are as straight as possible. Apply the parking brake or securely block the rear wheels to prevent the vehicle from moving forward or backward. **NEVER** get under the vehicle until you are sure that these steps are completed.

1. If the vehicle has been modified such that it is not equipped with the OE steering damper mounts, it must be restored to the original configuration in accordance with Chrysler Company specifications prior to installation of the Bilstein steering dampers.
2. Remove the OE steering damper from the vehicle. Save the bolt and locknut from the side closest to the wheel, as they will be re-used. The bolt and locknut from the side mounted to the axle will not be re-used. Refer to Figure 1.



Figure 1

3. Install one of the Bilstein steering dampers in the OE steering damper location using the OE bolt and locknut that was saved in step 2. Temporarily hand tighten. Make sure the damper is oriented so the piston rod end is mounted towards the wheel as shown in Figure 2. Do not install the other end yet.



Figure 2

E4-WM5-Y525A00 MOUNTING INSTRUCTION



Using the provided Bill of Materials on page 1, gather the following items:

Item #	Description	Qty
1	Lower mounting bracket	1
2	Upper mounting bracket	1
3	Socket Head Cap Screw, M8x1.25, L=30mm	4

4. Install the mounting brackets so they are clamped around the tie rod as shown in Figures 3 and 4. Make sure the BILSTEIN lettering is facing towards the front of the vehicle. Place one drop of Blue loctite® on the end of each of the screw threads, then thread the 4 socket head cap screws through the upper mounting bracket and into the lower mounting bracket. Thread them in just enough to hold the bracket assembly on the tie rod for now, but loose enough so the bracket can be adjusted on the tie rod.

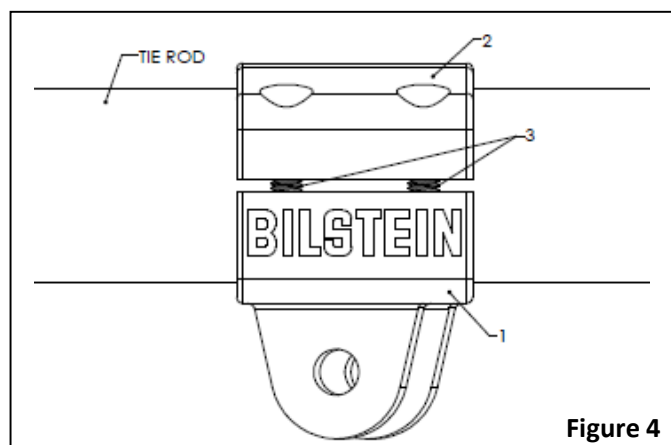
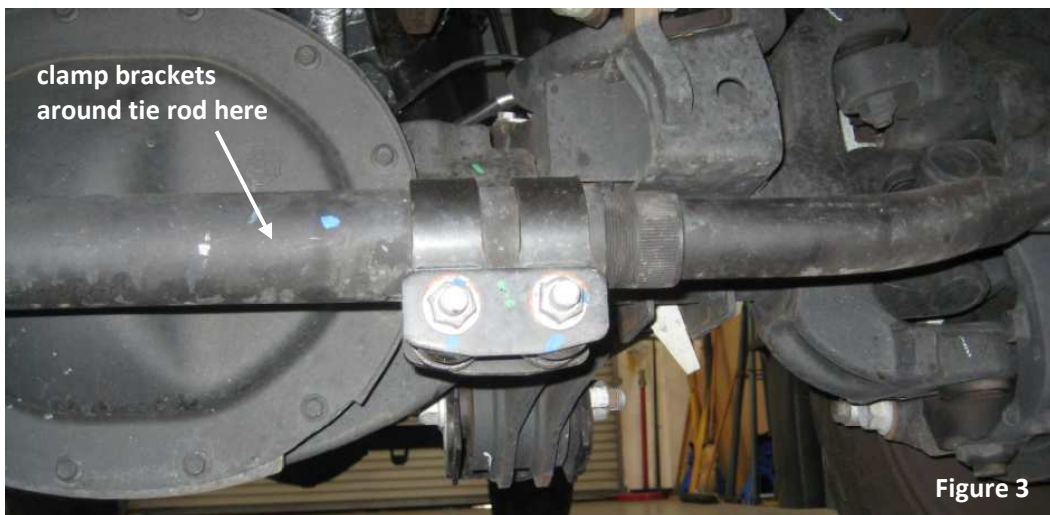

5. Using a tape measure, position the Bilstein mounting bracket so that the horizontal distance between the center of the Bilstein mounting bracket and the center of the OE mounting bracket attached to the axle is 19 11/32" (491mm). See Figure 11 on page 7.

E4-WM5-Y525A00 MOUNTING INSTRUCTION



6. Tighten the 4 socket head cap screws down so the bracket can no longer move. Re-measure to confirm the position relative to the OE mounting bracket attached to the axle is still 19 11/32" (491mm) and reposition as necessary. Once this measurement is confirmed, tighten the 4 socket head cap screws to 15N•m (11 lb•ft) in an "X" pattern. Ensure that the upper and lower brackets remain aligned with each other while tightening the socket head cap screws by taking note of the gap in between them (front vs rear). Now tighten the 4 socket head cap screws to 25N•m (18 lb•ft) in an "X" pattern.

Using the provided Bill of Materials on page 1, gather the following items:

Item #	Description	Qty
7	Hex Head Cap Screw, M12x1.75, L=110mm	1
8	Spacer, 12.1mm ID, L=6.5mm	1
9	Flange Locknut, M12x1.75	1

7. Slide the Hex Head Cap Screw (item #7) through the mount on the 2nd Bilstein steering damper (the one that hasn't been installed yet) as shown in Figure 5. Then slide the spacer (item #8) over the Hex Head Cap Screw (item #7) as shown in Figure 5.

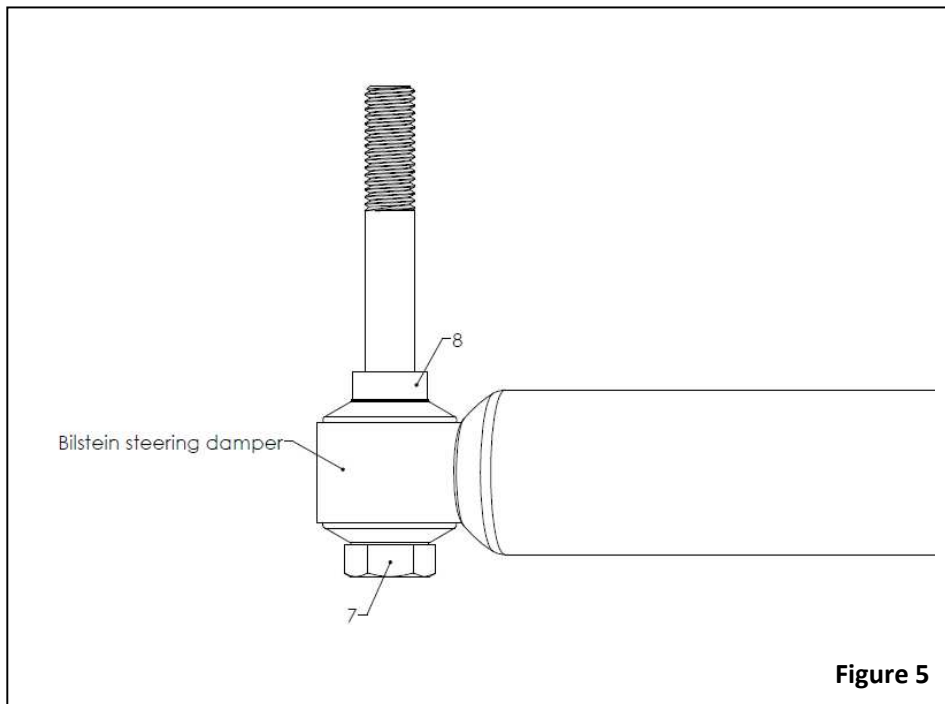

Figure 5

E4-WM5-Y525A00 MOUNTING INSTRUCTION



- Next, install the above assembly through the OE bracket on the axle and through the 1st Bilstein steering damper that was partially installed in step 3. *TIP* Use the OE bolt to position the 1st steering damper in the OE bracket on the axle. Thread the Flange Locknut (item #9) onto the Hex Head Cap Screw (item #7) and temporarily hand tighten. Refer to Figure 6 below and Figure 10 on page 7.



Using the provided Bill of Materials on page 1, gather the following items:

Item #	Description	Qty
4	Hex Head Cap Screw, M12x1.25, L=80mm	1
5	WASHER, 12mm	2
6	Nylock Nut, M12x1.25	1

- Slide one of the washers (item #5) onto the Hex Head Cap Screw (item #4). Then compress the 2nd Bilstein steering damper and align the eye loop with the clevis hole on the lower mounting bracket. Install the Hex Head Cap Screw (item #4) through the clevis hole and damper eye loop as shown below in Figure 7.

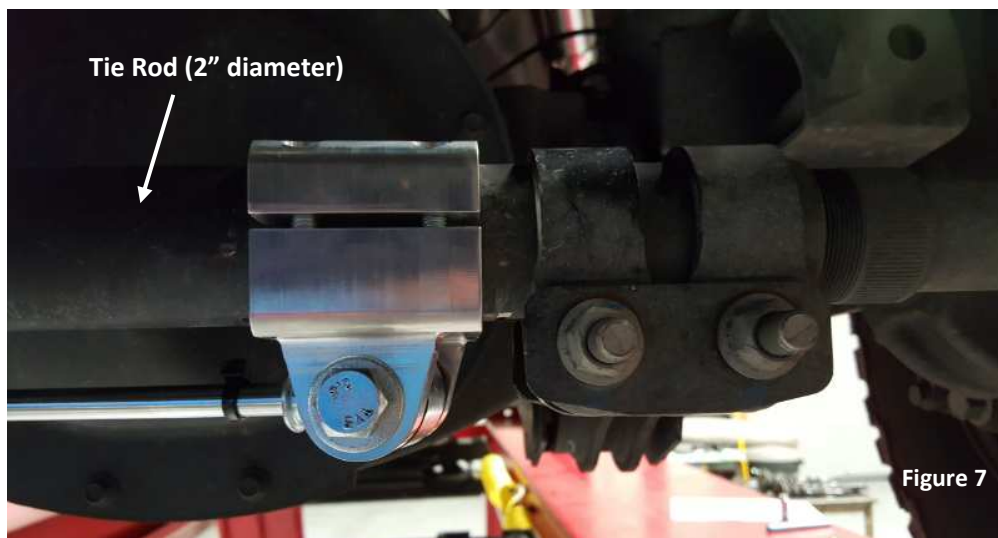

E4-WM5-Y525A00 MOUNTING INSTRUCTION



10. Install the other washer (item #5) over the end of the Hex Head Cap Screw (item #4). Thread the Nylock Nut (item #6) onto the Hex Head Cap Screw (item #4) and torque to 45N•m (33 lb•ft). See Figures 8 and 9 below.



Figure 8

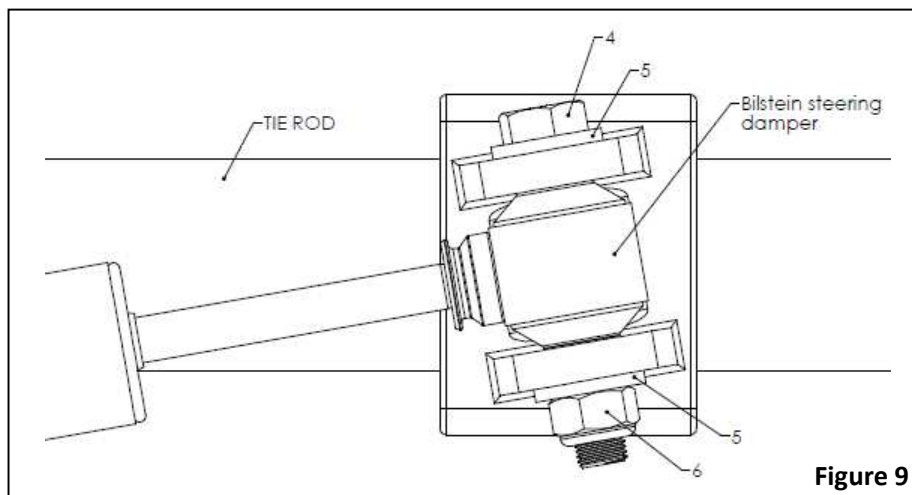

Figure 9

11. Now tighten the Flange Locknut (item #9) that was temporarily hand tightened in step 8. Torque to 70N•m (52 lb•ft).
12. Tighten the OE bolt and locknut that was saved in step 2 and hand tightened in step 3. Torque to the service manual specification.
13. With the vehicle running, carefully turn the steering wheel from full left turn lock to full right turn lock and check for any interference between the steering dampers, mounting brackets and any other components on the vehicle. Verify the second steering damper is not over compressing or over extending during the steering sweep. If it is over compressing or over extending, refer to step 5 and Figure 11 for the correct position of the Bilstein mounting bracket on the tie rod.
14. This completes the installation. See Figures 10 and 11 on the next page for pictures of the completed install.

E4-WM5-Y525A00
MOUNTING INSTRUCTION



First steering damper (in OE steering damper location)



Second steering damper location



Check out the collection of performance steering parts we offer.