

E4-WM5-Y301A00 MOUNTING INSTRUCTION



Removal

Place vehicle on a chassis hoist,
lift it and remove wheel



The lower control arm must be supported by suitable means!

Remove top and bottom mount.

Remove complete shock absorber
and original mounting parts.

Fitting

Fit BILSTEIN and/ or original mounting parts
on BILSTEIN shock absorber in reverse
sequence to removal.

Fit BILSTEIN shock absorber to the vehicle
in reverse sequence of removal.

All rubber- mounted strut/ damper attachments
must not be fully tightened until AFTER the
suspension system is loaded (wheels on the
ground). Other mounting fasteners (for example
brackets) must be securely tightened BEFORE
load is placed on the suspension system.

list of torques

	M8	M 10	M 12	M 14	M 16	Thread
	13	25	45	72	110	Torque Nm
	10	19	34	54	83	Torque ft lb

FOR THE REMOVAL AND INSTALLATION
OF NUTS, IMPACT TOOLS MUST NOT
BE USED BECAUSE THIS WOULD DAMAGE
THE MOUNT THREADS.
SELF- LOCKING NUTS MUST
ONLY BE **USED ONCE!**



ALL DIAGRAMS ARE GENERALIZED
AND NOT TO SCALE!
BRACKETS, ETC. SPECIFIC TO
STRUT ARE NOT SHOWN!

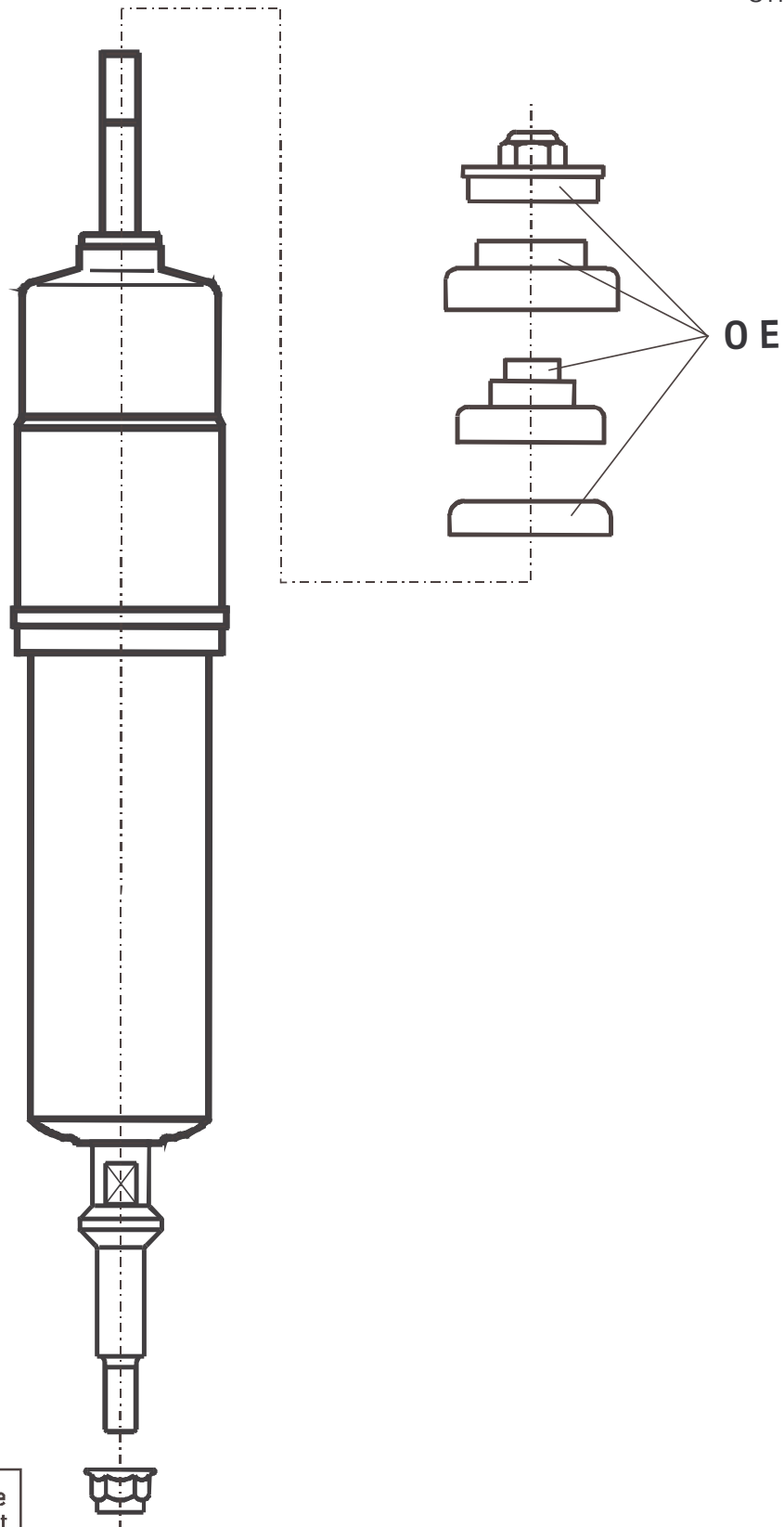

OE = Original Anbauteile
Original Equipment