

INSTALL/REMOVAL INSTRUCTIONS: BLEND DOOR

ATTENTION: Refer to the appropriate shop manual for your vehicle to obtain specific service procedures for this part. If you do not have a service manual or lack the skill to install this part, it is recommended that you seek the services of a qualified technician. Pay special attention to all cautions and warnings included in the shop manual. Read and follow all instructions carefully.

ATTENTION: Refer to the appropriate shop manual for your vehicle to obtain specific service procedures for this part. If you do not have a service manual or lack the skill to install this part, it is recommended that you seek the services of a qualified technician. Pay special attention to all cautions and warnings included in the shop manual. Read and follow all instructions carefully.

902-322

Dodge RAM 02-08 Mode Door

Installation Instructions

Packing list:

- Metal blend door
- Metal duct tape

Tools required:

- Screw driver, pliers
- Socket wrench set
- Dremel® tool (with flexible extension)
- Optional: shop vac, flashlight

1. Disconnect the negative terminal of the battery.
2. Remove the plastic covering over the glove box and lower portion of the center control panel.

Fig. 1

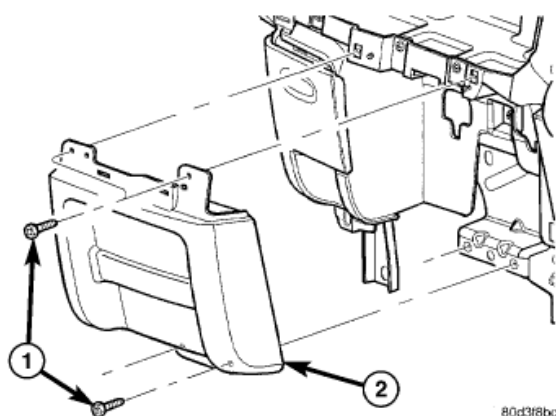
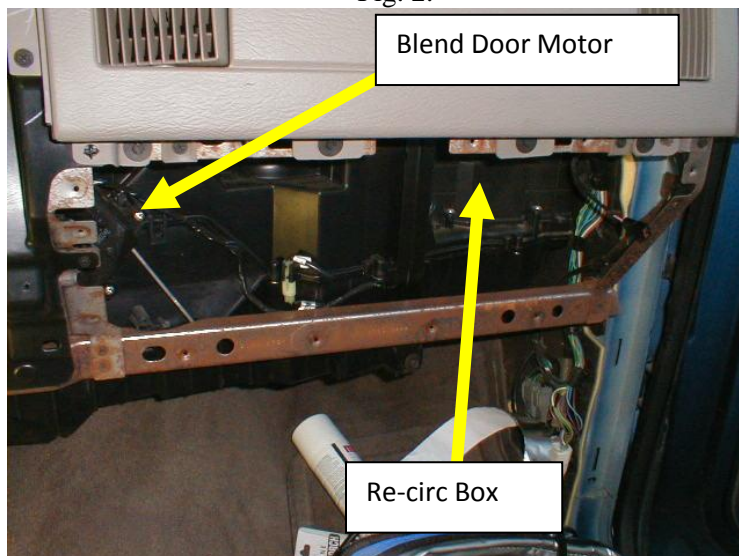

Fig. 21 STORAGE BIN

- 1 - SCREWS (4)
- 2 - STORAGE BIN

Fig. 2.



DORMAN®

Disclaimer:

Even though every attempt is made to ensure this information is complete and accurate, it is impossible to account for all possible circumstances or situations. Please consult with a qualified auto technician before attempting to perform any work you are not qualified to do. Automobiles can be hazardous to work on; be sure to take all necessary safety precautions. Failure to do so may result in property damage or personal injury. Certain motor vehicle standards and performance requirements may apply to our motor vehicle (such as Federal Motor Vehicle Safety Standards by the National Highway Traffic Safety Administration). Be sure that your work is performed in accordance with such standards and that you do not disable any motor vehicle safety feature.

INSTALL/REMOVAL INSTRUCTIONS: BLEND DOOR

ATTENTION: Refer to the appropriate shop manual for your vehicle to obtain specific service procedures for this part. If you do not have a service manual or lack the skill to install this part, it is recommended that you seek the services of a qualified technician. Pay special attention to all cautions and warnings included in the shop manual. Read and follow all instructions carefully.

Fig. 3

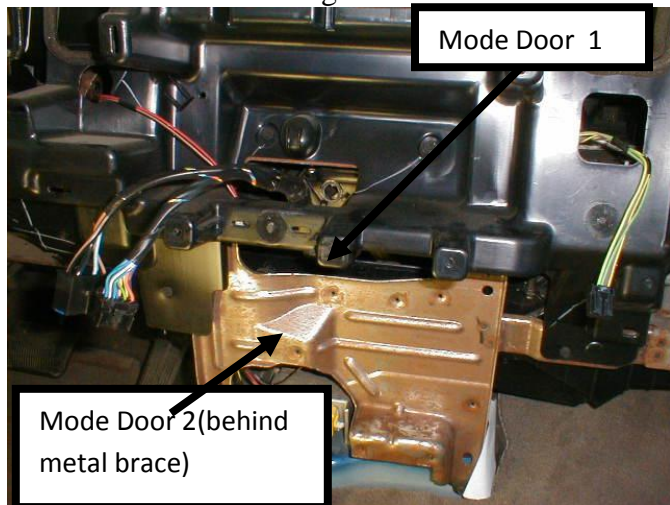

Fig 4b

Fig. 4a

3. The remainder of the instruction set will be divided into segments addressing each door assembly. Skip through sections that do not apply to your needs.

Mode Door 1

1. Check Fig. 4b for location of the actuator motor. This actuator is accessible through a hole in the metal brace and the repair can be done without removing the metal brace. The process is similar to replacing the blend door and we won't go into the same detail on the repair. You may want to read through the Blend Door section above.
2. Remove the actuator motor and examine the axle and limit pin. You can also manually move the door to check for correct operation.
3. Cut into the box and remove the broken door. The white connector can be wedged out with a screw driver or pulled with a pair of pliers. This component will not be re-used, so don't worry about damage. Cut-out pattern is shown in Fig. 10.

Disclaimer:

Even though every attempt is made to ensure this information is complete and accurate, it is impossible to account for all possible circumstances or situations. Please consult with a qualified auto technician before attempting to perform any work you are not qualified to do. Automobiles can be hazardous to work on; be sure to take all necessary safety precautions. Failure to do so may result in property damage or personal injury. Certain motor vehicle standards and performance requirements may apply to our motor vehicle (such as Federal Motor Vehicle Safety Standards by the National Highway Traffic Safety Administration). Be sure that your work is performed in accordance with such standards and that you do not disable any motor vehicle safety feature.

INSTALL/REMOVAL INSTRUCTIONS: BLEND DOOR

ATTENTION: Refer to the appropriate shop manual for your vehicle to obtain specific service procedures for this part. If you do not have a service manual or lack the skill to install this part, it is recommended that you seek the services of a qualified technician. Pay special attention to all cautions and warnings included in the shop manual. Read and follow all instructions carefully.

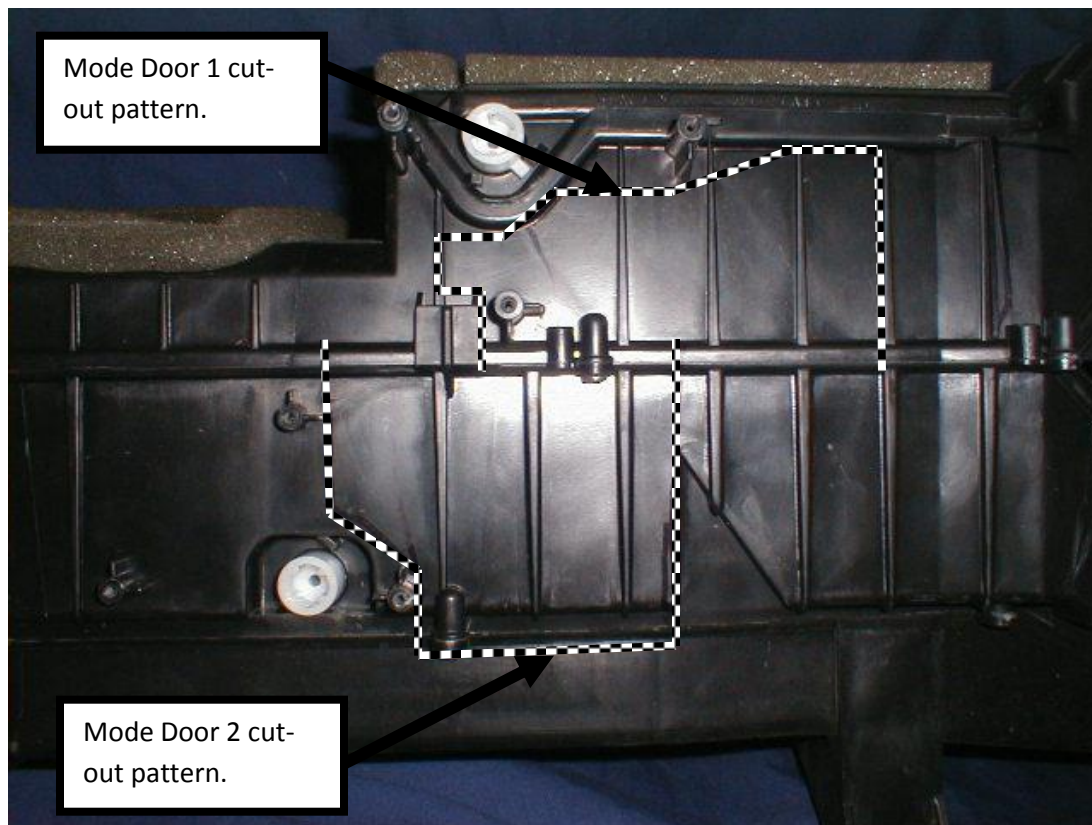

Fig. 10

Disclaimer:

Even though every attempt is made to ensure this information is complete and accurate, it is impossible to account for all possible circumstances or situations. Please consult with a qualified auto technician before attempting to perform any work you are not qualified to do. Automobiles can be hazardous to work on; be sure to take all necessary safety precautions. Failure to do so may result in property damage or personal injury. Certain motor vehicle standards and performance requirements may apply to our motor vehicle (such as Federal Motor Vehicle Safety Standards by the National Highway Traffic Safety Administration). Be sure that your work is performed in accordance with such standards and that you do not disable any motor vehicle safety feature.

INSTALL/REMOVAL INSTRUCTIONS: BLEND DOOR

ATTENTION: Refer to the appropriate shop manual for your vehicle to obtain specific service procedures for this part. If you do not have a service manual or lack the skill to install this part, it is recommended that you seek the services of a qualified technician. Pay special attention to all cautions and warnings included in the shop manual. Read and follow all instructions carefully.

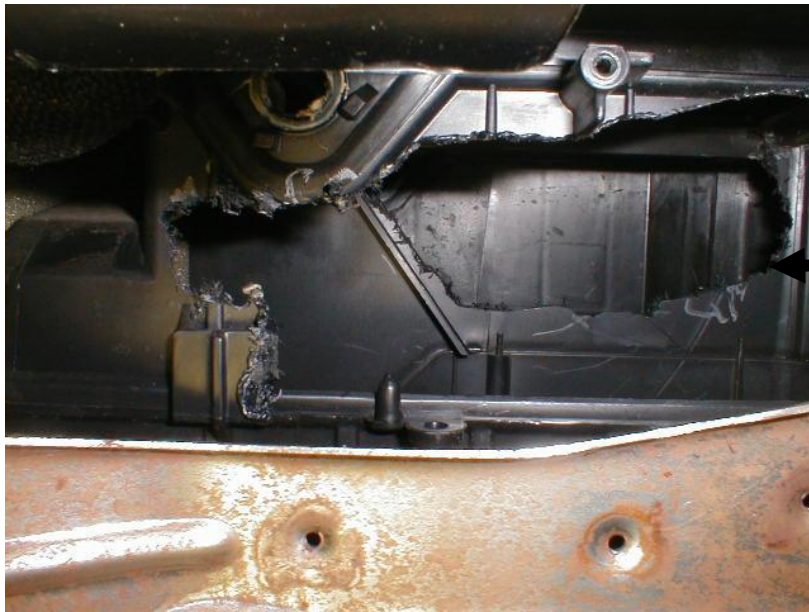

Center divider cut
pattern.

Fig. 11

4. **Replace the motor, fitting the connector into the new axle. Position of the door is not critical since the computer will self-calibrate the door.**
5. **Seal the opening and check that the wire is connected to the motor. DONE.**

Disclaimer:

Even though every attempt is made to ensure this information is complete and accurate, it is impossible to account for all possible circumstances or situations. Please consult with a qualified auto technician before attempting to perform any work you are not qualified to do. Automobiles can be hazardous to work on; be sure to take all necessary safety precautions. Failure to do so may result in property damage or personal injury. Certain motor vehicle standards and performance requirements may apply to our motor vehicle (such as Federal Motor Vehicle Safety Standards by the National Highway Traffic Safety Administration). Be sure that your work is performed in accordance with such standards and that you do not disable any motor vehicle safety feature.